

## CONTENTS

### MATERIAL HANDLING

On-a-Roll Lifters®	2
On-a-Roll Lifter® Low Profile & Jumbo	4
On-a-Roll Lifter® Standard Models, Hi-Rise & Compact	6
On-a-Roll Lifter® Grande & Spinner	8
Gorilla Grippers	40

### VERTICAL MULTI-SUBSTRATE CUTTERS

SteelTraK & Accessories	10
Excalibur 5000	14
Excalibur 1000X & Accessories	15

### PRECISION CUTTER BARS, STRAIGHT EDGES WORKBENCHES & STANDS

Evolution-E2 & Accessories	16
Evolution 2 Bench	18
Javelin Integra & Javelin Series 2	20
Simplex & Accessories	21
Big Bench Xtra & Surface Mounted Lift & Hold	22
Proteus Workbench & Precision Straight Edges	23
Sabre Series 2, Stands & Stand Packages	24

### FABRIC CUTTERS & STANDS

Hot Cut System, Stands & Stand Packages	26
Heat Knife Carriers & Heat Knives	27

### FLEXO PLATE CUTTERS

Flexo Futura Plate Cutter	28
---------------------------	----

### MAT CUTTERS

Ultimat Futura	30
Ultimat Gold & Futura Upgrade Kits	31

### ROTARY TRIMMERS

Advanced Rotary Cutter & Table-Edge Trimmer	32
Professional, DigiTech & Stands	34
MonoRail	35
Technical, PowerTech & Stands	36

QUICK REFERENCE BLADE GUIDE	38-39
-----------------------------	-------

WARRANTY GUIDE	40
----------------	----

FOSTER PARTNER



Academic Representative:



Technology Education Concepts

# Foster

Keencut Work Benches Rotatrim On-a-Roll Lifter®



**THE KEENCUT EVOLUTION-E2** integrated wide format cutting system vastly improves the speed, accuracy and convenience of the finishing process.

**THE KEENCUT 98" STEELTRAK** was developed specifically for the tougher and thicker rigid and semi-rigid substrates used in today's sign making market.



**NEW**



**FOSTER ON-A-ROLL LIFTER® JUMBO** is perfect for businesses operating grand- or extra-wide printers, fabric printers, or those handling floor coverings and similar materials.

[www.TECedu.com/foster-cutters](http://www.TECedu.com/foster-cutters)  
1-800-338-2238 • [moreinfo@TECedu.com](mailto:moreinfo@TECedu.com)



Low Profile Lifter  
Model # 61574

## Foster On-a-Roll Lifters

In any shop handling rolls of print media or other material, a Foster On-a-Roll Lifter® is a must-have tool. Here are just a few reasons:

- Material damage is reduced or eliminated when moving rolls.
- Large media and heavy material rolls are handled quickly and easily.
- The simple hydraulic foot pump makes lifting effortless.
- Nylon safety straps enable one operator to move even the heaviest media rolls.
- An On-a-Roll Lifter® model is available to accommodate virtually every printer available.

“Our new Foster On-a-Roll Lifter® makes loading our HP 3100 Latex printer a breeze. Handling our big substrate rolls formerly required two or three operators. Now one can do it alone — even in the tight space behind the printer.”

– Justin Acklin,  
Production/Installation Supervisor,  
Quick Change Display, Las Vegas, NV USA



If your business involves handling rolls of print media, fabric, flooring or any other material, Foster has an On-a-Roll Lifter® for the job.

### **SIGN MAKERS:**

On-a-Roll Lifters enable everyone in the shop to do the heavy lifting associated with unwieldy media and substrate rolls.

### **WIDE-FORMAT PRINTERS:**

An On-a-Roll Lifter makes material handling anyone's job.

### **DISPLAY MANUFACTURERS:**

Foster offers a complete range of On-a-Roll Lifters—one for virtually every printer available and for every shop layout.

### **FABRIC PRINTERS:**

Jumbo material rolls are no problem with the Foster On-a-Roll Lifter.

### **FLOOR GRAPHICS:**

Use an On-a-Roll Lifter in both the shop and the warehouse.

### **CONVERTERS:**

The On-a-Roll Lifter Spinner simplifies loading rolls and eliminates awkward and potentially injurious roll maneuvering.

### **WIDE WEB LABEL PRINTERS:**

Positioning media rolls is simple, and expensive pressure sensitive material damage is reduced.



1. Nylon safety straps allow solo users to pull media rolls into the securing tray for transport.



2. The easy-to-use foot pump allows users to raise the material for transport with minimal effort.



3. Heavy-duty rotating casters allow users to navigate through standard doors and narrow passages.



4. Pushing awkward rolls around corners is no longer a concern.



5. Slide your media rolls right up to the printer for efficient loading.

## Here's how to specify the right lifter for your application



Have questions? Call us at 800-523-4855. The entire Foster team is at your service.

# On-a-Roll Lifter® LOW PROFILE

Lift rolls as heavy as 660 lbs (300 kg) and as wide as 16 feet 5 inches (5 m), with diameters as great as 15.75 inches (40 cm). With a 3.25 inch (82.5 mm) clearance of the bottom fork, it's a perfect complement to HP Latex 1500, 3000, 3100, and 3500 printers.

MODEL 61574

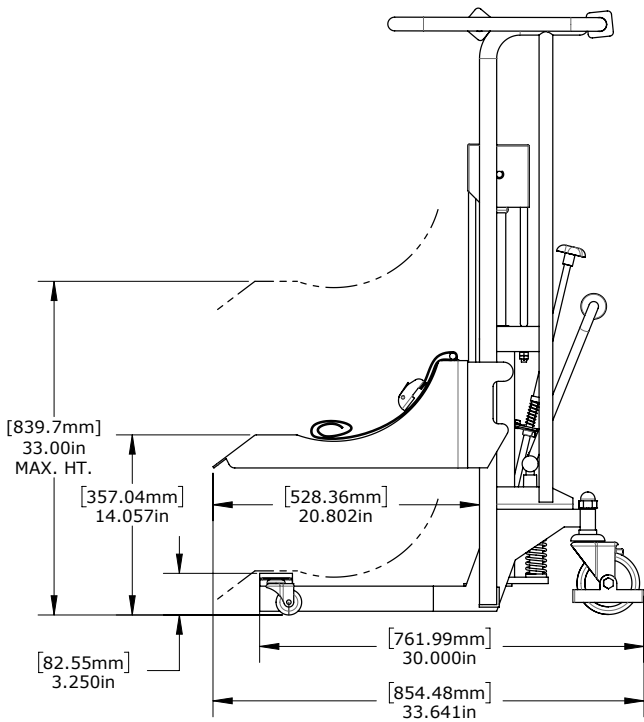

## SPECIFICATIONS

Roll Weight Capacity.....	300 kg (660 lbs)
Lift Height .....	84 cm (33")
Max. Roll Width .....	5 m (16'5")
Max. Roll Diameter .....	40 cm (15.75")
Width x Depth.....	111.6 cm x 85.5 cm (44" x 33.6")
Height.....	119.4 cm (47")
Weight.....	85 kg (188 lb)
Bottom Fork Clearance .....	8.25 cm (3.25")



Tray cut out for easy maneuvering around floor mounted brackets.

Small front casters reduce the front fork height.



The large tray is specifically designed to handle large diameter, heavy rolls.

## On-a-Roll Lifter® JUMBO

One operator can easily lift rolls as heavy as 990 lbs (450 kg), as wide as 16 feet 5 inches (5 m), and with diameters as great as 19.6 inches (50 cm). Designed for EFI, Reggiani and Matan printers, the Foster On-a-Roll Lifter Jumbo is perfect for businesses operating grande- or extra-wide printers, fabric printers, or those handling floor coverings and similar materials.

MODEL 61577

### SPECIFICATIONS

Roll Weight Capacity.....	450 kg (990 lbs)
Lift Height .....	1500 mm (59")
Max. Roll Width .....	5 m (16'5")
Max. Roll Diameter .....	500 mm (19.6")
Width x Depth.....	1200 mm x 774.8 mm
.....	(47.24" x 30.51")
Height.....	1555 mm (61.22")
Weight.....	134 kg (295 lbs)
Bottom Fork Clearance .....	110 mm (4.3")

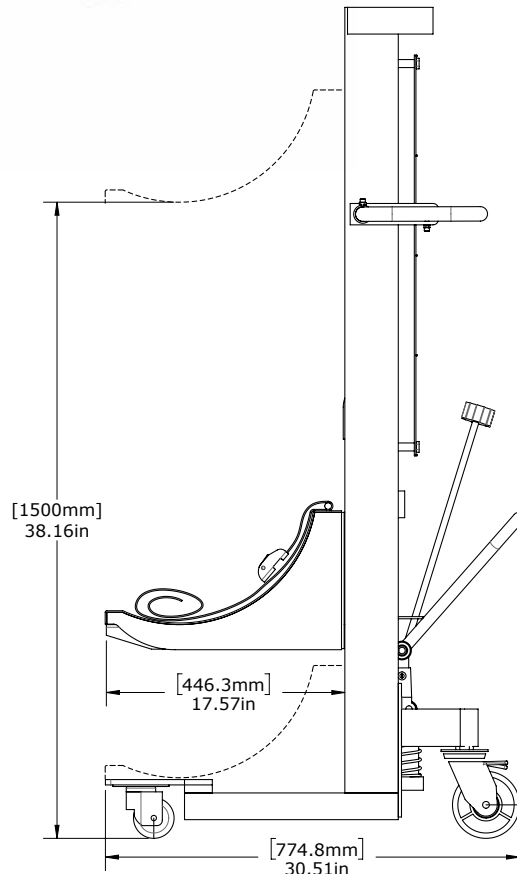

**FOR MOST APPLICATIONS, CHOOSE FROM THE MOST POPULAR FOSTER ON-A-ROLL LIFTERS.**

Most popular is the Standard lifter (Model 61584, or its big brother Model 61586, which handles longer rolls). Choose the Hi-Rise or Compact lifters (Models 61570 and 61579) if the application has limited space or high bay storage requirements. Any of these lifters permit a single operator to move heavy media or material rolls anywhere in the shop, including delivery to printers. All are balanced lifters, providing safe, reliable movement of media wherever it is needed.

## On-a-Roll Lifter® STANDARD MODELS

Designed specifically for sign makers and other businesses with the need to handle wide or heavy media rolls. It enables users to quickly and effortlessly lift media as heavy as 660 lbs (300 kg) and as wide as 16 feet 5 inches (5 m), with diameters as great as 15.75 inches (40 cm). The ergonomic pull bar allows users to maneuver around tight corners and through narrow passages.



Ergonomic push bar permits easily maneuvering of large, heavy rolls.

MODEL 61584 & MODEL 61586

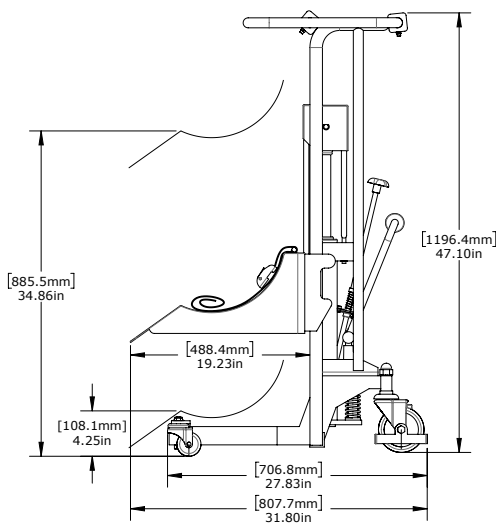

SPECIFICATIONS	STANDARD MODEL 61584	STANDARD MODEL 61586	HI-RISE MODEL 61570	COMPACT MODEL 61579
Roll Weight Capacity	300 kg (660 lbs)	300 kg (660 lbs)	200 kg (440 lbs)	90 kg (200 lbs)
Lift Height	85 cm (33.5")	85 cm (33.5")	1.8 m (71")	85 cm (33.5")
Max. Roll Width	2.5 m (8'2")	5 m (16'5")	1.2 m (47.25")	1800 mm (72")
Max. Roll Diameter	40 cm (15.75")	40 cm (15.75")	47 cm (128.5")	30.5 cm (12")
Width x Depth	80 cm x 80 cm (31.5" x 31.5")	120 cm x 80 cm (47.25" x 31.5")	85 cm x 80 cm (33.5" x 31.5")	57.4 cm x 79.6 cm (22.6" x 31.34")
Height	119.4 cm (47")	119.4 cm (47")	320.5 cm (80.7")	107.9 cm (42.48")
Weight	80 kg (177 lbs)	85 kg (188 lbs)	90 kg (198 lbs)	80 kg (177 lbs)
Bottom Fork Clearance	10 cm (4")	10 cm (4")	10 cm (4")	11.7 cm (4.63")

# On-a-Roll Lifter® HI-RISE

A rugged lifter designed specifically for fabric printers, sign makers, converters, grand- and wide-format printers, or any business with the need to lift heavy media or fabric rolls. Sturdy steel construction permits lifting rolls as heavy as 440 lbs (200 kg) nearly 6 ft (180 cm). Solves the problem of loading converting machines or printers with high inputs. Enables fabric printers to easily lift rolls onto tall production tables for spreading, sewing, or finishing. Permits using higher than normal storage for media or fabric rolls.

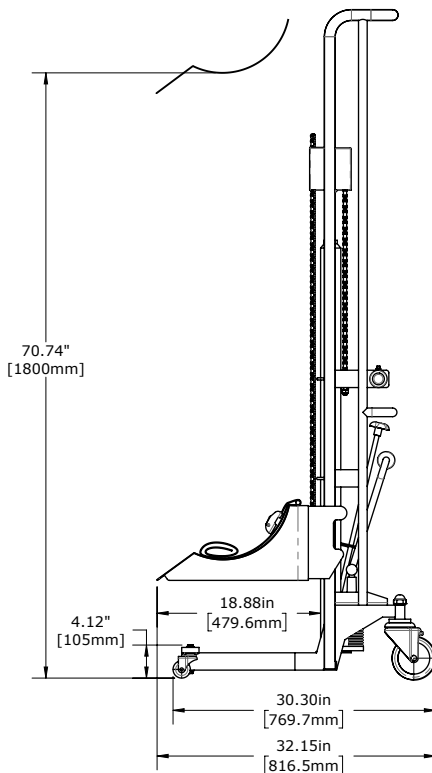

MODEL 61570

# On-a-Roll Lifter® COMPACT

Designed specifically for sign makers and other businesses with the need to handle heavy media rolls. It enables users to quickly and effortlessly lift media as heavy as 200 lbs (90 kg) and as wide as 72 inches (1800 mm), with diameters as great as 12 inches (30.5 cm). The compact design allows the user to maneuver around tight corners and through narrow passages. Designed to operate even in shops with limited floor space.



Ideal for tight areas with little maneuvering room!

MODEL 61579

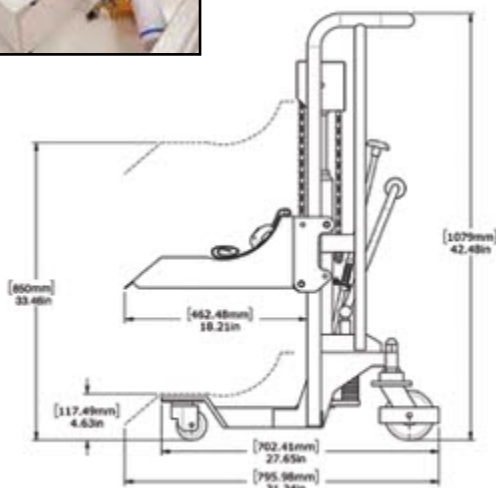

# On-a-Roll Lifter® GRANDE

Need a workhorse lifter that can manage large or heavy rolls? The Foster On-a-Roll Lifter Grande is just the ticket. Designed specifically for roll converters, package printers, and other businesses needing to handle very heavy media, this beefy lifter lets one operator move rolls as heavy as 1,540 lbs (700 kg). The specially designed tray accommodates rolls for easy loading and unloading, as well as transporting.

**MODEL 61590**

## SPECIFICATIONS

Roll Weight Capacity.....	700 kg (1540 lbs)
Min. Tray Height .....	170 mm (6.69")
Lift Height .....	865 mm (34")
Front Swivel Casters .....	4"
Rear Swivel Casters .....	6"
Max. Roll Width .....	1550 mm (61")
Max. Roll Diameter .....	800 mm (31.49")
Width x Depth.....	681.2 mm x 1263.3 mm
	(26.82" x 49.74")
Height.....	1120.1 mm (44.1")
Bottom Fork Clearance .....	159 mm (6.3")

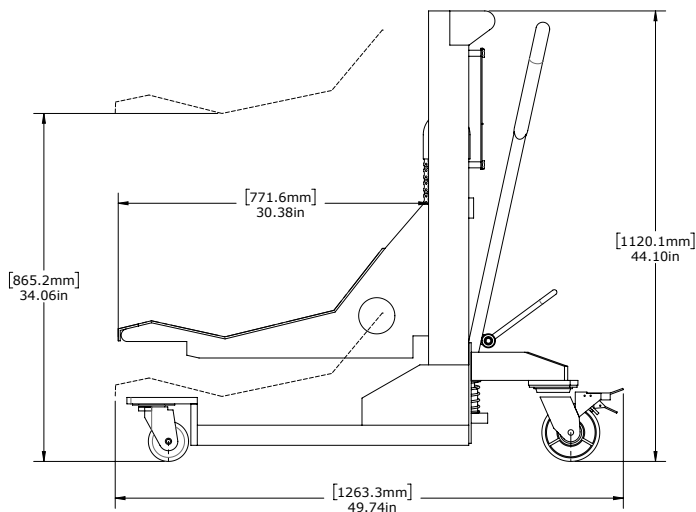

Shown at Keystone Converting, Montgomeryville, PA



# On-a-Roll Lifter® SPINNER

Need a better way to load and unload heavy rolls of media for converting? Operators sick of wrestling heavy rolls out of inventory and on to the converting station?

The Foster On-a-Roll Spinner makes life easier for operators. When it spins the roll, the centrifugal force locks the roll in place on the differential shaft. For unloading, the roll is spun in the opposite direction and the clutch releases.

Bi-directional rollers permit spinning the roll in either direction.

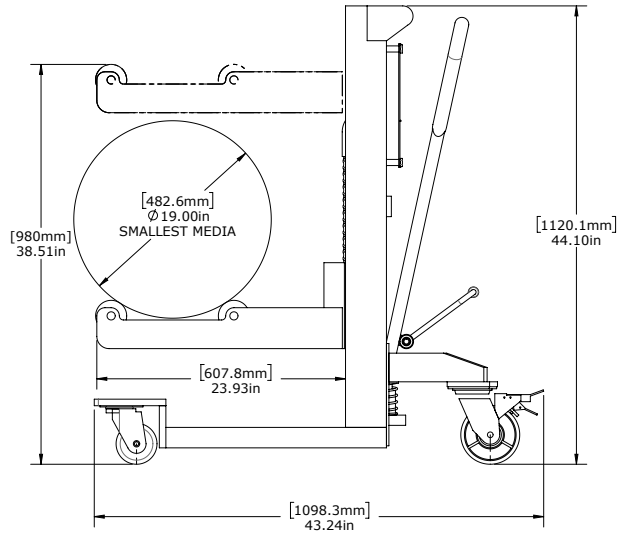

## MODEL 61592

### SPECIFICATIONS

Roll Weight Capacity.....	700 kg (1540 lbs)
Lift Height .....	865 mm (34")
Front Swivel Casters.....	4"
Rear Swivel Casters .....	6"
Max. Roll Width .....	1550 mm (61")
Max. Roll Diameter .....	610 mm (24")
Width x Depth.....	700 mm x 1098.3 mm
	(27.56" x 43.24")
Height.....	1120.1 mm (44.1")
Bottom Fork Clearance .....	159 mm (6.3")



Shown at Keystone Converting, Montgomeryville, PA

## SteelTraK

Developed specifically for the tougher and thicker rigid and semi-rigid substrates used in today's sign making market, the heavy-duty SteelTraK handles oversized materials with ease. With a cut length option of 65", 82" or 98", it is the longest, most accurate and easiest-to-use manual vertical cutter available.

### STATE-OF-THE-ART COUNTERBALANCE

The spine of the SteelTraK is fitted with a counterbalance that allows users to put the head in any position without it dropping to the bottom of the machine. The cumbersome process involved with other vertical cutters – lifting the head, applying the brake, and screwing it in place while simultaneously loading the material – is eliminated. The counterbalance eliminates the load from the cutting head, and because operators are not lifting the full weight of the head, they can concentrate solely on cutting the material. The end result: time savings and productivity gains.

### HEAVY-DUTY DESIGN

A robust frame includes extruded aluminum back beams that support sheets of all sizes and prevent offcuts (including flexible materials) from falling through the frame. The one-piece squaring arm makes calibrating the SteelTraK easy to achieve accurate cuts.



**98" STEELTRAK**  
MODEL #60383

BIG Print Shop, in Richland, Washington, specializes in vinyl banners, trade show displays, fabric backdrops, canvas prints, flyers, business cards, and more. Says Kelly Edwards, the owner; "We love the SteelTraK because of how easily and accurately every cut is made. We use it to trim foamcore, Gatorboard, Dibond® and fluted yard signs, and rely on the SteelTraK cutter to save us time and yield a perfectly finished product every time. It lets us keep costs down while providing affordable quality to every customer."

– Kelly Edwards, BIG Print Shop owner, demonstrates the SteelTraK cutter.





### Easily Adjustable **THREE-IN-ONE CUTTING TOOL**

All three cutting tools are attached to the cutting head.

With just a turn of the wheel, select:

- 1 UTILITY BLADE for up to 1/2" thick materials
- 2 ACRYLIC SCORING
- 3 COMPOSITE TWIN-WHEEL CUTTING HEAD



### **ALL BLADES CUT ON THE SAME LINE**

One-stop setting - One measurement - One cutline cursor - No special operator training - No laser shake - Less operator fatigue - No wasted panels - No mistakes. Accepts standard utility blades for general purpose cutting. Ratchet control lets the operator control blade depth and cutting action.



### **COMPOSITE TWIN WHEEL CUTTING HEAD - NOISELESS & DUST-FREE**

Heavy duty steel composite twin wheel cutting head. Twin Wheels cut aluminum composite in one clean pass. Optional Aluminum Twin Wheel Cutting Head for 0.040" aluminum panels.

### **FULL LENGTH EXTRA-GRIP CLAMPING SYSTEM**

Engage by simply using the Clamp Handle. Grips material firmly, yet protects preprinted surfaces with non-marking silicon rubber grip cords.



### **QUICK SET PRODUCTION STOPS**

Fitted as standard with a pair of left and right Quick Set Production Stops for fast and accurate one-off and production cutting. For added convenience, additional production stops are available as an optional accessory.



### **PERMA-LOCK SQUARING**

Precise screw-adjusted perma-lock squaring for accurately cut panels every time.



### **LOW FRICTION BALL BEARINGS ON A STEEL TRACK FOR ULTRA-SMOOTH OPERATION**

Pre-lubricated ball bearings on steel slide tracks for precision, low friction and years of trouble-free life without adjustment. 20-year replacement guarantee on all sliding bearings.

## QUICK LOOK

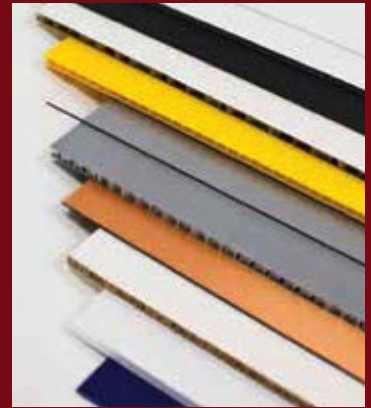

### **CUTS UP TO 1/2":**

- Acrylic \*\* (up to 1/4", scoring & snapping)
- Aluminum (0.040") \*
- Aluminum composite (up to 4mm)
- Corrugated plastic
- Foam board
- Flexible polycarbonate (up to 3mm)
- Gatorboard®
- Glass \* (up to 1/4", scoring & snapping)
- MDF (up to 3mm)
- PVC board \*\*

\* with optional cutting tools

\*\* some restrictions may apply to acrylic, glass and PVC materials on the 98" model.

### **INCLUDES:**

- Wall mount kit
- Cutting tools
- Medium-duty utility blades (100)
- Acrylic scoring blade
- Composite twin-wheel cutting tool

*See our Warranty Guide on the back cover.*

## SteelTraK *continued*

3 Sizes to Choose From: 65", 82" & 98"



**98" STEELTRAK**  
MODEL #60383  
98" CUT SIZE  
OVERALL SIZE:  
121"H x 87 1/2"W x 36" - 49"D

This strong, reliable vertical cutter handles full size 4'x8' boards.

Added features include:

- Vertical cutting length of 98" (250cm).
- The main body encloses a balance weight system so that the cutting head can be suspended at any height.
- Change blades in an instant, with no need to lift the heavy duty cutting head.
- Ease of cutting wide media using a dual counterbalance and Pull Bar system.

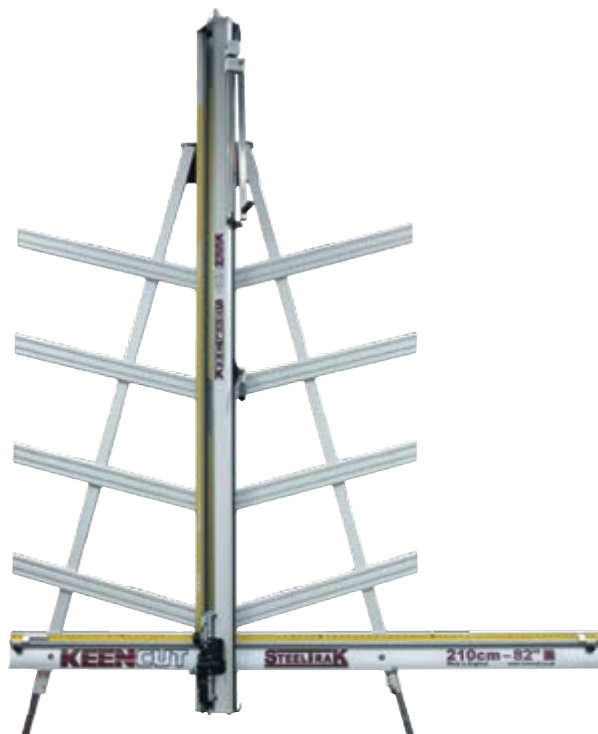

**82" STEELTRAK**  
MODEL #60385  
82" CUT SIZE  
OVERALL SIZE: 110"H x 84 3/4"W x 12"-16"D



**65" STEELTRAK**  
MODEL #60380  
65" CUT SIZE  
OVERALL SIZE: 98"H x 84 3/4"W x 12"-16"D

# SteelTraK Accessories



## V-GROOVE CUTTING TOOL

Manufactured from hardened high-carbon tool steel, the optional V-Groove cutting tool is perfect for making trays, trade show display stands and light boxes at a fraction of the cost and in a fraction of the time required by larger equipment. The V-Groove device cuts a “v” out of the back of the material — for instance, in aluminum composite — through one section of aluminum and through the plastic core, permitting the material to be folded to 90°.

### MODEL # DESCRIPTION

69142	2mm
69143	3mm
69144	4mm
69146	6mm
69147	Replacement V-Groove blade
69148	Replacement V-Groove blade (Pack of 5)

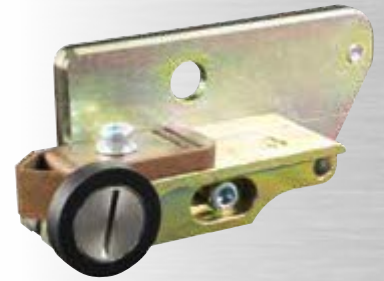

65" SteelTraK shown with the Freestanding Kit



## ALUMINUM TWIN-WHEEL CUTTING TOOL

Cuts up to 0.040" (1 mm) aluminum sheet material in a single pass. The cutting wheels are made of high-carbon hardened steel.

MODEL #69127

## FREESTANDING KIT

The freestanding kit bolts directly to the back of the SteelTraK, creating a rigid, freestanding cutting unit. The freestanding kit is ideal when wall space is limited or machine placement flexibility is required.

### MODEL # DESCRIPTION

66002	Freestanding kit for 65" SteelTraK
66003	Freestanding kit for 82" SteelTraK
66004	Freestanding kit for 98" SteelTraK

## SQUARING ARM EXTENSION

MODEL #69149

## GLASS CUTTING KIT (no image shown)

MODEL #69129

## SITE LINE STRIPS

MODEL #69117 (Pack of 3)

## REPLACEMENT BLADES & CUTTING WHEELS

### MODEL # DESCRIPTION

69126	Composite twin wheels only
69128	Aluminum twin wheels only
69108	Medium-duty blades (100)
69114	Tungsten carbide glass wheel
69119	Superior quality blades (100)

See our Quick Reference Blade Guide on p. 38-39.

# EXCALIBUR 5000

With the Keencut Excalibur 5000, modern sign makers, framers, photographers, educators and reprographics industries have access to four precision cutters in one:

a twin-wheel cutting head, a utility blade, a scoring blade for acrylic and a tungsten carbide glass scoring wheel.

**DESIGNED FOR PROFESSIONALS IN THE FRAMING, PHOTOGRAPHY, EDUCATION AND REPROGRAPHICS INDUSTRIES** The Excalibur trims a wide range of sheet materials accurately and in square, with minimum effort.

**PRESSURE SENSITIVE CLAMP:**

Permits lining up the board to a hold position, but allows it to be moved under the clamp for final alignment. The harder the clamping handle is pushed, the firmer the grip on the board.

**ONE-PIECE SQUARING ARM:**

The horizontal squaring arm is machined from one single, heavy duty aluminum extrusion. The left and right sides are in perfect alignment.

**FLIP STOPS:**

Two flip stops make cutting-to-size easy. Flip stops can be engaged or disengaged without disturbing the settings.

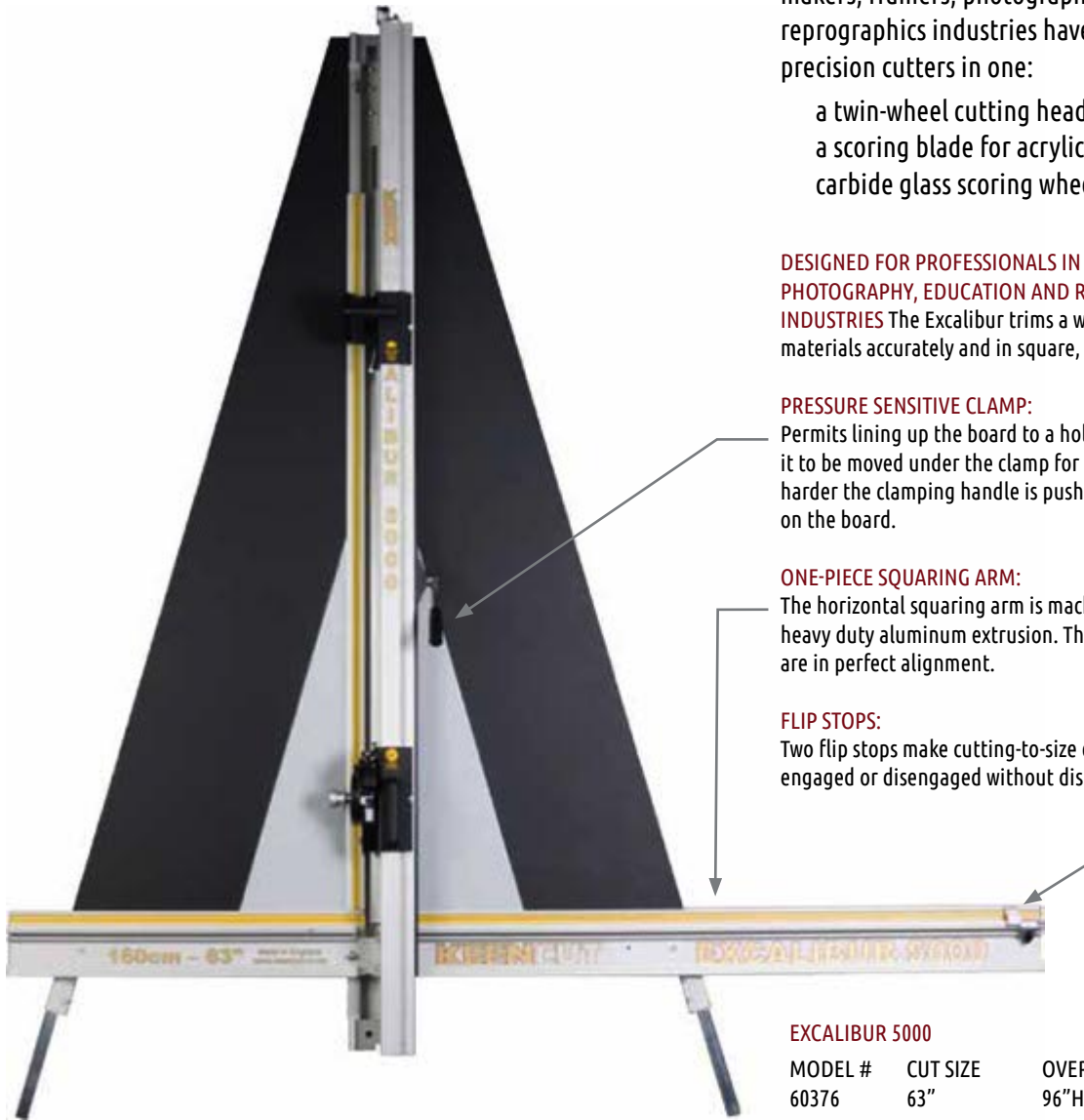

**EXCALIBUR 5000**

MODEL #	CUT SIZE	OVERALL SIZE
60376	63"	96"H x 84"W x 12-16"D

## EXCALIBUR 5000 CUTTING HEAD

**EFFORTLESS LIFTING**

The Excalibur 5000 features a unique counterbalance that ensures an easy-glide cutting action, prevents damage when loading sheet materials, minimizes operator fatigue and increases production. When released, the balanced cutting head stays in the last position, ready for the next operation. The counterbalance weight can be transferred to the upper twin wheel or lower multi-blade cutting head with the flip of a switch.

**FOUR PRECISION CUTTERS IN ONE:** a twin-wheel cutting head, a utility blade, a scoring blade for acrylic and a tungsten carbide glass scoring wheel.



Freestanding Kit  
MODEL #66002



# EXCALIBUR 1000X

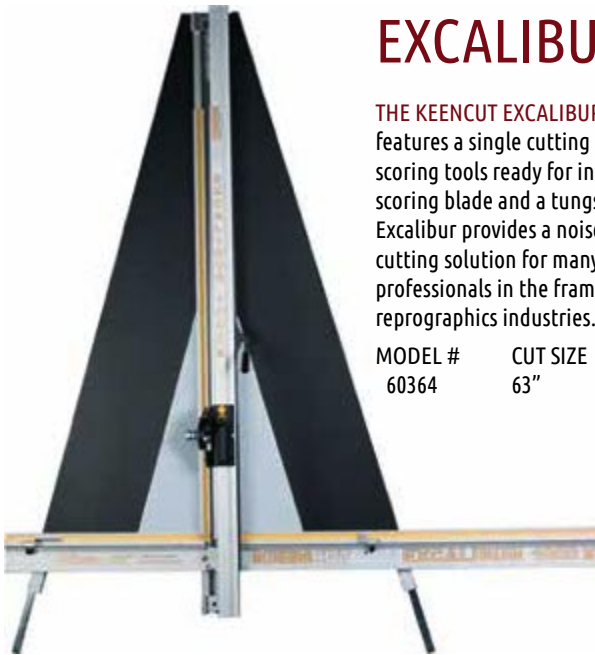

## THE KEENCUT EXCALIBUR 1000X

features a single cutting head with three cutting and scoring tools ready for instant use: a utility blade, a scoring blade and a tungsten carbide glass cutting wheel. Excalibur provides a noiseless, dust-free and cost effective cutting solution for many of the materials used by professionals in the framing, photography, education and reprographics industries.

MODEL #	CUT SIZE	OVERALL SIZE
60364	63"	96"H x 84"W x 12-16"D

## EXCALIBUR 5000 AND 1000X UNIQUE FEATURES

- **Cutting-Line Indicator:** A clear plastic strip along the left side of the vertical cutting bar accurately indicates the cut line. All tools cut along the same cut line.
- **Vertical Cutting Bar:** When clamped down, there is no gap between the cutting bar and the surface of the material being cut. The vertical cutting bar is steel reinforced and will not bend or flex even when cutting dense, thick materials.
- **Ratchet Control:** The built-in ratchet permits cutting up to 1/2" thick PVC in multiple passes if required. Notch the cutter to the depth required, take the cut, repeat notching until the full depth is created.
- **Wall Mount Kit:** Secure the Excalibur to a wall at the top of the cutter. Two telescopic legs allow customization to suit the height of the user. A freestanding kit is available for use in the workshop floor.

## ACCESSORIES



Composite  
Twin-wheel head  
Model # 69125

## FREESTANDING KIT

MODEL #66002  
(shown to left)

The freestanding kit bolts directly to the back of the Excalibur 5000 or Excalibur 1000X to create a rigid, freestanding cutting unit. The freestanding kit is ideal when wall space is limited or machine placement flexibility is required.

## SITE LINE STRIPS

MODEL #69117 (Pack of 3)

## REPLACEMENT BLADES & CUTTING WHEELS

MODEL #	DESCRIPTION
69108	Medium-duty blades (100)
69109	Scoring blade for acrylic (5)
69119	Superior quality blades (100)
69114	Tungsten carbide glass wheel
69125	Composite twin-wheel head
69110	Cutting wheels only (2)

See our Quick Reference Blade Guide on p. 38-39.

## QUICK LOOK

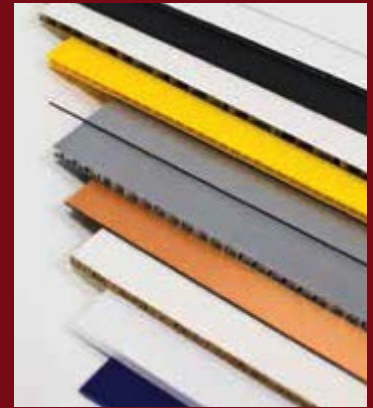

CUTS ALL THESE MATERIALS AND MORE.

## PERFECT FOR CUTTING:

Twin-wheel Cutting Head  
(Excalibur 5000 only)

- Mat board (1/8")
- Polycarbonate (1mm)
- Masonite board (1/8")

Scoring Blade:

- Acrylic/Plexiglas (1/4")

Utility Blade Up to 1/2":

- Cardboard
- Foam board
- Gatorboard®
- Honeycomb board
- Honeycomb plastics
- PVC foam

Tungsten Carbide Wheel  
Up to 1/4" thick:

- Glass
- Mirrors

## INCLUDES:

- Wall mount kit
- Cutting tools
- Medium-duty utility blades (100)
- Tungsten carbide glass scoring wheel
- Twin-Wheel cutting head (Excalibur 5000 Only)

See our Warranty Guide on the back cover.



### High Performance BI-DIRECTIONAL CUTTING HEAD

The Evolution-E2 features a high-performance double cutting head that accepts two blade holders at one time, making it ideal for bi-directional cutting. The long-lasting Graphik blades can be interchanged quickly, maximizing productivity.

### EVOLUTION -E2 INCLUDES 3 CUTTING HEADS



**GRAPHIK BLADE HOLDER X2**  
MODEL #60396

These unique reversible blades favor both left- and right- handed operators and cut materials up to 1/2". The blades also can be set at different depths, allowing the first blade to score the material and the second blade to cut through it, all in a single pass.

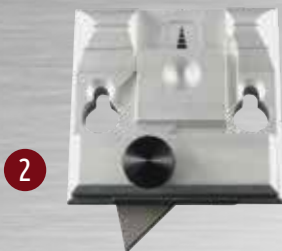

**MEDIUM-DUTY BLADE HOLDER**  
MODEL #60395

The medium-duty utility blade holder accepts standard utility blades and cuts up to 3/8" thick.

Outstanding features deliver the ultimate in precision, versatility and speed to any workshop.



**TEXTILE BLADE HOLDER**  
MODEL #60397

Cold cut textiles and other delicate materials. Ideal for trimming thin strips off banners and posters where a knife blade would be too aggressive.

## Evolution-E2

The Keencut Evolution-E2 integrated wide format cutting system vastly improves the speed, accuracy and convenience of the finishing process.

- The cutting bar is weighted and has silicone bead strips embedded in the straight edge and base plate, providing additional grip, thus eliminating the need to manually hold material.
- Mounts to most bench surfaces via a series of adjustable mounting brackets designed to optimize alignment and clamping. Adjustable levelers ensure straight and accurate cuts to within 0.008" over the entire length of the cut, up to 144".
- Materials can also be secured flush against production work stops to hold them in place.
- A sturdy torsion bar enables a single operator to lift and control the entire cutter bar from either end, loading and aligning even the longest print jobs quickly and accurately.



### TEXTILE CUTTING TRACK

Hinge knobs can be loosened and the cutter slid back completely to use the built-in textile cutting track and textile cutting attachment (included). Ideal for cutting textiles and other delicate materials. Switch between cutting groove and cutting strip in only seconds.



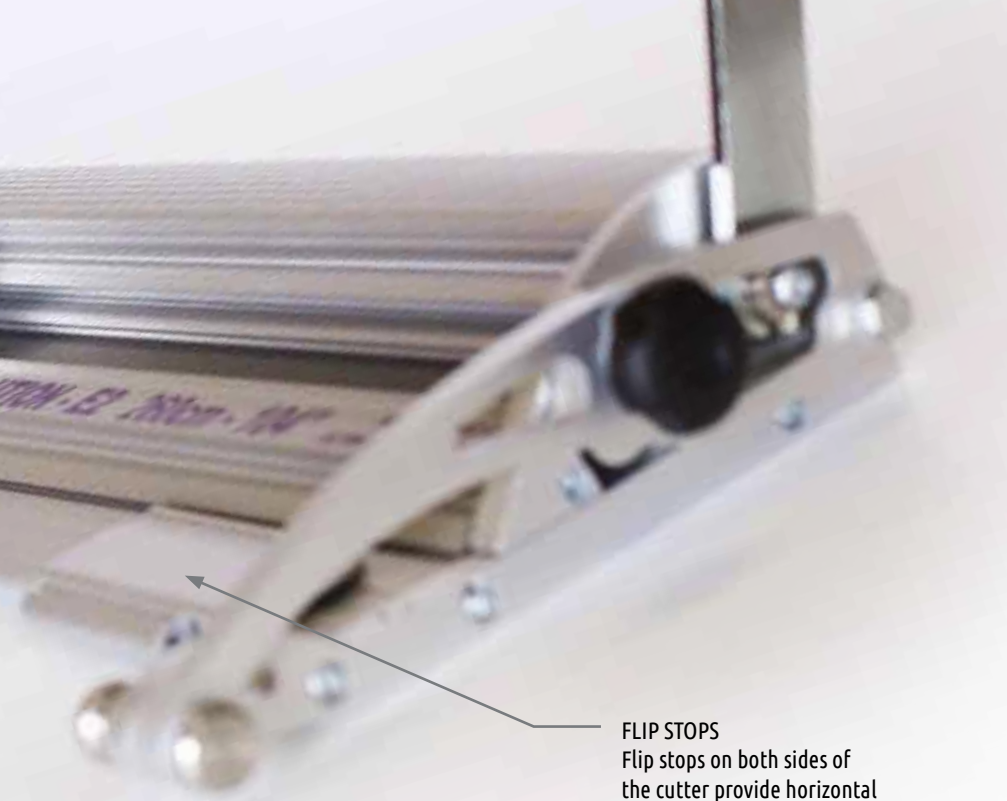

**FLIP STOPS**  
 Flip stops on both sides of the cutter provide horizontal clamping. The flip stops help keep material in place and improve clamping because material cannot move away from the blade.

**EVOLUTION-E2 MODELS**

MODEL #	CUT SIZE	OVERALL SIZE
60386	64"	76"W x 10"D
60387	84"	96"W x 10"D
60388	104"	115½"W x 10"D
60389	124"	135"W x 10"D
60390	144"	154¾"W x 10"D

**ACCESSORIES - REPLACEMENT BLADES & CUTTING WHEELS**

MODEL #	DESCRIPTION
69108	Medium-duty blades (100)
69119	Superior quality blades (100)
69132	45mm OLFA cutting wheels (10)
69133	45mm standard cutting wheels (10)
69131	Graphik D 0.017" blades (100)
60395	Medium-duty blade holder
60396	Graphik blade holder
60397	Textile blade holder
60195	Textile cutting strip, 15.6' long (2)
KX12	Yellow "T" silicone (Pack of 32')
KX14	Yellow round silicone (Pack of 32')



Graphik Blade  
 Model # 69131



Medium Duty Blade  
 Model # 69108

See our Quick Reference Blade Guide on p. 38-39.



**HEAT KNIFE**

**OPTIONAL:** When heat cutting and sealing is required, the optional Heat Knife Carrier can be quickly attached with the appropriate electric Heat Knife. Detaching it later takes only seconds.  
 MODEL # 60398

Learn more about Heat Knife Cutting on p. 27.

**QUICK LOOK**

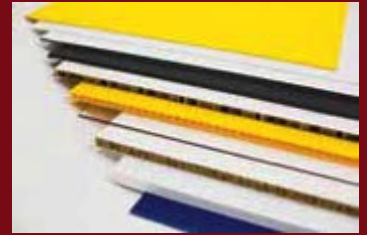

**CUTS ALL THESE MATERIALS AND MORE.**

**PERFECT FOR CUTTING:**

- Acrylic (up to ¼", scoring & snapping)
- Foam board
- Ink jet media
- Corrugated plastic
- PVC board (10mm)
- Fabric and Textiles
- Vinyl

**INCLUDES:**

- Graphik D 0.017" blades (25)
- Vertical Graphik blade holders (2)
- 1 textile blade holder with 45mm cutting wheel
- Vertical medium-duty blade holder
- Medium-duty blades (100)

See our Warranty Guide on the back cover.

## EVOLUTION 2 BENCH

Combine the Evolution 2 Bench and the Evolution-E2 cutter to create the ultimate precision cutting table.

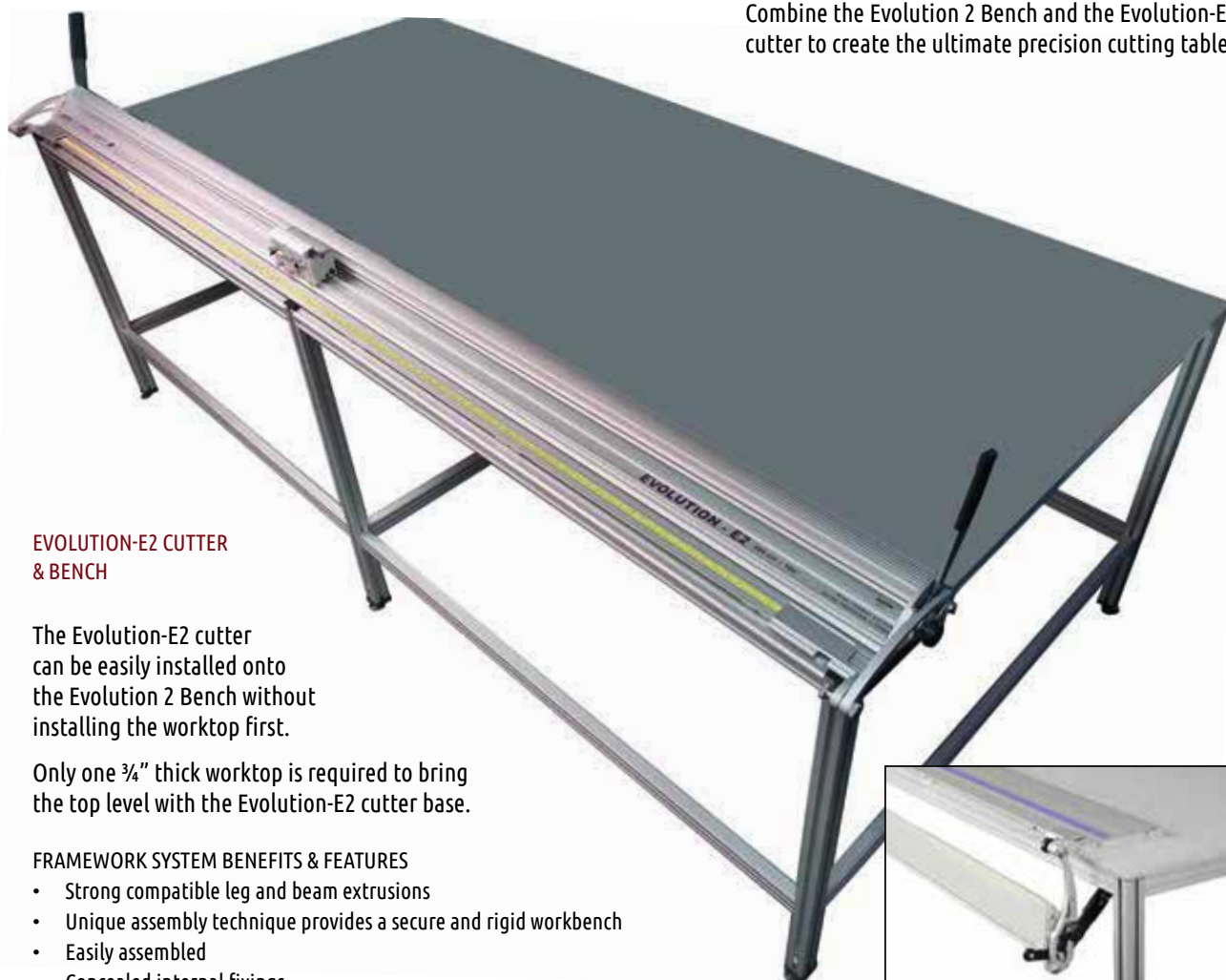

### EVOLUTION-E2 CUTTER & BENCH

The Evolution-E2 cutter can be easily installed onto the Evolution 2 Bench without installing the worktop first.

Only one 3/4" thick worktop is required to bring the top level with the Evolution-E2 cutter base.

#### FRAMEWORK SYSTEM BENEFITS & FEATURES

- Strong compatible leg and beam extrusions
- Unique assembly technique provides a secure and rigid workbench
- Easily assembled
- Concealed internal fixings
- Fully customizable
- Anodized for clean good looks and long life
- Assembly tools included



#### CUTTER BAR SWING-OVER

When not in use, the cutter bar swings over and folds under the cutting table or workbench, producing an unobstructed workbench surface.

"From our beginning in 2007 as a garage based shop hand-printing t-shirts for local bands, we have become a full-service provider of decorated apparel, adding advertising specialties and banners to our offerings. We have gone from outsourcing banners and signage to going fully vertical, allowing us to produce the full package internally. As we expanded, we carefully selected finishing equipment that would be useful in a wide variety of projects, and among the devices we acquired is the Foster Evolution-E2 Wide Format Cutter—a very versatile machine that enhances our ability to get jobs out quickly. Our business continues to expand, and we expect that the Foster Evolution-E2 will help us streamline production and pay for itself many times over."

— John Bowes, Owner, Cold Cuts, Hatfield, PA, USA. [www.coldcutsprints.com](http://www.coldcutsprints.com)



## EVOLUTION 2 BENCH FEATURES



**ADJUSTABLE FEET**  
Adjustable for precise bench leveling on uneven floors to help maintain flatness and obtain maximum, uncompromised accuracy.

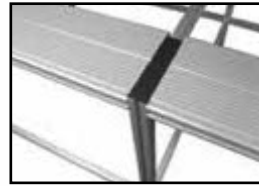

**INTEGRAL ALUMINUM BASE**  
The Evolution 2 Bench comes complete with framework and aluminum base for quick and easy mounting of the Evolution-E2 for accurate one-off and production cutting. For added convenience, additional production stops are available as an optional accessory.



**UNIQUE LOCKING SYSTEM**  
Strong leg and beam extrusions allow many different size and shape configurations. Internal locking brackets enhance the smooth appearance and allow solid panels to be fitted without obstruction.



**WORKTOP FIXING BRACKETS**  
Create the ideal bench surface using a variety of worktop fixings (worktop not included).



## ADDITIONAL MODELS AND ACCESSORIES

DESIGNED SPECIFICALLY FOR THE EVOLUTION-E2 CUTTER BAR  
The Evolution Bench framework system enables fast and easy assembly. All necessary tools are included.

### EVOLUTION 2 BENCH

MODEL #	EVOLUTION 2 BENCH SIZES	CUSTOMER-SUPPLIED TOP WORKTOP SIZE	CUTTER SIZE
60950	For the 64" Evolution-E2	76 3/8" L x 47 1/4" W x 3/4" H	64"
60951	For the 84" Evolution-E2	96" L x 47 1/4" W x 3/4" H	84"
60952	For the 104" Evolution-E2	115 3/4" L x 47 1/4" W x 3/4" H	104"
60953	For the 124" Evolution-E2	135 1/2" L x 47 1/4" W x 3/4" H	124"
60954	For the 144" Evolution-E2	155" L x 47 1/4" W x 3/4" H	144"



EVOLUTION 2 BENCH

### EVOLUTION 2 BENCH OPTIONAL EXTENSION KITS

Two depths: Extend bench depth by 71cm (28") using the Small Extension Kit  
Extend bench depth by 129cm (52") using the Large Extension Kit

MODEL #	EXTENSION BENCH SIZES
60980	71cm (28") Depth Extension for 64" Evolution Bench
60981	71cm (28") Depth Extension for 84" Evolution Bench
60982	71cm (28") Depth Extension for 104" Evolution Bench
60983	71cm (28") Depth Extension for 124" Evolution Bench
60984	71cm (28") Depth Extension for 144" Evolution Bench
60985	129cm (50.75") Depth Extension for 64" Evolution Bench
60986	129cm (50.75") Depth Extension for 84" Evolution Bench
60987	129cm (50.75") Depth Extension for 104" Evolution Bench
60988	129cm (50.75") Depth Extension for 124" Evolution Bench
60989	129cm (50.75") Depth Extension for 144" Evolution Bench



SMALL EXTENSION KIT

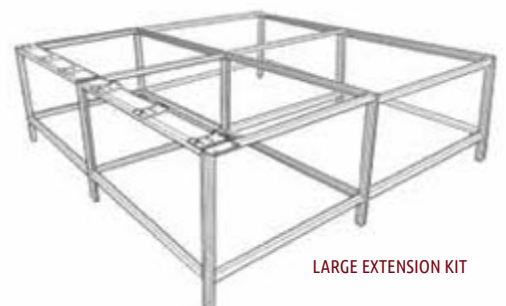

LARGE EXTENSION KIT

See our Warranty Guide on the back cover.

## SIGN MAKING & WIDE FORMAT GRAPHICS

Precision Cutter Bars, Straight Edges & Fabric Cutters



JAVELIN  
INTEGRA



# Javelin Integra & Javelin Series 2

## JAVELIN INTEGRA

The Javelin Integra combines the portability of the Javelin Series 2 with the table-mounted convenience of the Evolution-E2 and includes:

- Accuracy to within 0.008" over the full length of the cut.
- Javelin Integra features a perfectly balanced Lift and Hold System, allowing for easy material loading.
- A fixed docking port that prevents the unit from moving when applying pressure to thick materials. The Javelin Integra is simply fastened to an existing flat bench surface with screws or to a Proteus Bench (p. 23) to create a complete cutting station in your workshop. The unit can be easily lifted off the base and stored or used as a portable cutter bar.
- A full-length aluminum cutting track for the blade tip to run along, avoiding cut damage to the underlying table. (No need to manually saw a slot into your workbench to accommodate the blade.) Integrated silicon strip to hold materials securely while clamped.



**SERIES 2 CUTTING HEAD**  
MODEL #60394  
High-Performance Cutting Head.  
Tools interchange quickly for  
maximum productivity.

JAVELIN SERIES 2 INCLUDES 3 CUTTING HEADS



## JAVELIN SERIES 2

The accuracy of the Javelin Series 2 makes it ideal for cutting banner materials, pop-ups and other display materials that require precise and accurate cutting to within 0.008" over the full length of the cut. With this precise cutter, gaps and wasted material are eliminated.

Javelin Series 2 cutter bars may also be combined with the Surface Mounted Lift and Hold Mechanism (p. 22) or the Big Bench Xtra (p. 22) to create a complete cutting solution.



1

**GRAPHIK BLADE HOLDER**  
MODEL #60396  
Unique reversible blades favor both left- and right-handed operators and cut materials up to 1/2".



2

**TEXTILE BLADE HOLDER**  
MODEL #60397  
Cold cut textiles and other delicate materials. Ideal for trimming thin strips off banners and posters where a knife blade would be too aggressive.



3

**MEDIUM-DUTY BLADE HOLDER**  
MODEL #60395  
The medium-duty utility blade holder accepts standard utility blades and cuts up to 3/8" thick.

# Simplex Blades & Accessories



## SIMPLEX

### THE SIMPLEX IS MORE THAN A STRAIGHT EDGE.

It's a lightweight, portable straight edge mounted with a quality cutting head that features utility knife blades. The cutting head permits blade depth adjustment and accepts utility blades that cut to a depth of 3/8", as well as XR blades that cut to a depth of 1/2".

Use on a floor or a bench; the Simplex is accurate to within 0.03" over the full length of the cut and is an economical alternative to the Javelin Series 2 or Sabre Series 2. Full-length silicone rubber grip strips protect material and ensure that it is held securely.

### SIMPLEX

MODEL #	CUT SIZE	OVERALL SIZE
60455	44"	50"W x 6"D x 2 1/2"H
60456	64"	70 3/4"W x 6"D x 2 1/2"H
60457	84"	89 1/2"W x 6"D x 2 1/2"H
60458	104"	109 1/4"W x 6"D x 2 1/2"H
60459	124"	128 3/4"W x 6"D x 2 1/2"H

### OPTIONAL ACCESSORIES & BLADES FOR SIMPLEX

MODEL #	DESCRIPTION
69108	Medium-duty blades (100)
69109	Scoring blade for acrylic (5)
69119	Superior quality blades (100)
69120	XR long blades (100)
69140	28mm textile cutting tool
69141	28mm cutting wheels (10)
KX12	Yellow "T" silicone (Pack of 32')
KS11/003	Replacement Series 1 cutting head

### JAVELIN INTEGRA

MODEL #	CUT SIZE	OVERALL SIZE
60286	64"	72"W x 6 1/2"D x 8"H
60287	84"	91 3/4"W x 6 1/2"D x 8"H
60288	104"	111 1/4"W x 6 1/2"D x 8"H
60289	124"	131"W x 6 1/2"D x 8"H

### JAVELIN SERIES 2

MODEL #	CUT SIZE	OVERALL SIZE
60275	44"	50"W x 6"D x 2 1/2"H
60276	64"	70 3/4"W x 6"D x 2 1/2"H
60277	84"	89 1/2"W x 6"D x 2 1/2"H
60278	104"	109 1/4"W x 6"D x 2 1/2"H
60279	124"	129"W x 6"D x 2 1/2"H

### OPTIONAL ACCESSORIES & BLADES FOR JAVELIN INTEGRA & JAVELIN SERIES 2

MODEL #	DESCRIPTION	MODEL #	DESCRIPTION
69131	Graphik D 0.017" blades (100)	60394	Replacement Series 2 Cutting Head
69108	Medium-duty blades (100)	KX14	Yellow round silicone cord (Pack of 32') (Javelin Integra only)
69119	Superior quality blades (100)	KX12	Yellow "T" silicone cord (Pack of 32')
69132	45mm OLFA cutting wheels (10)		
69133	45mm standard cutting wheels (10)		

See our Quick Reference Blade Guide on p. 38-39.



### 28MM TEXTILE CUTTING TOOL

Model 60397  
Cold cut textiles and other delicate materials. Ideal for trimming thin strips off banners and posters where a knife blade would be too aggressive.

## QUICK LOOK

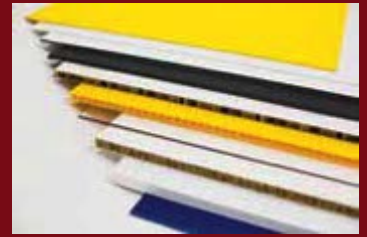

CUTS ALL THESE MATERIALS AND MORE.

PERFECT FOR CUTTING UP TO 1/2":

- Acrylic (score & snap up to 1/4")
- Corrugated plastic
- Foam board
- Film
- Tissue
- Banners
- Fabric and Textiles (simplex- with optional textile cutting tool)

JAVELIN INTEGRA AND JAVELIN SERIES 2 INCLUDES:

- Vertical Graphik blade holder
- Graphik D 0.017" blades (10)
- 1 textile blade holder with 45mm cutting wheel
- Vertical medium-duty blade holder
- Medium-duty blades (100)
- Integral base with a lift and hold mechanism (Javelin Integra)

SIMPLEX INCLUDES:

- Medium-duty blades (100)

See our Warranty Guide on the back cover.

## Big Bench Xtra

The Keencut Big Bench Xtra improves the accuracy and function of Javelin Series 2 precision cutter bars. Designed with a built in cutting base plate and a Lift and Hold mechanism on each side of the table, the Big Bench Xtra enables users to easily align and trim the largest work projects single-handedly. Aluminum base-plate with leveling system, integrated cutting groove & full-length grip strip for clamping. Constructed from anodized aluminum for long-lasting durability, the Big Bench Xtra makes cutting tables and workstations solid and precise.



**BIG BENCH XTRA**  
 Big Bench shown with Javelin.  
 Worktop (not included)  
 ¾" MDF board recommended.



### SHARED BENCH FEATURES

PRODUCED USING THE PROTEUS FRAMEWORK SYSTEM

- Strong compatible leg and beam extrusions
- Unique construction provides a secure and rigid work bench
- Assembly is quick and easy
- Concealed internal fixings
- Fully customizable
- High grade anodizing for clean good looks
- 5 year warranty
- Assembly tools included

### ADDITIONAL MODELS & ACCESSORIES

BIG BENCH XTRA (for Javelin Series 2)

MODEL #	SIZE	CUSTOMER-SUPPLIED TOP	OVERALL SIZE
60928	44"	49"W x 31"D x ¾"H	53"W x 36"D x 35¼"H
60930	64"	69"W x 31"D x ¾"H	73"W x 36"D x 35¼"H
60932	84"	88"W x 31"D x ¾"H	92"W x 36"D x 35¼"H
60934	104"	108"W x 31"D x ¾"H	112"W x 36"D x 35¼"H
60936	124"	128"W x 31"D x ¾"H	132"W x 36"D x 35¼"H

### SURFACE MOUNTED LIFT & HOLD MECHANISM

(for Javelin Series 2)

MODEL #60970

Surface Mounted Lift & Hold Mechanism

Surface Mounted Lift and Hold Mechanism is the simple way to integrate an existing cutter bar onto a workbench or table.

Designed to fit the Javelin Series 2 precision cutter bar, the Surface Mounted Lift and Hold Mechanism is affixed to the table by screws, securing the cutter bar in place and preventing shifting while cutting. The device allows operators to easily lift the cutter bar, slide the material in place and clamp it down to make precision cuts. Supplied as a set of two mechanisms — Left & Right.



Surface Mounted Lift & Hold Show with Javelin Series 2

# Proteus Workbench & Straight Edges

The Keencut Proteus Workbench, combined with the Javelin Integra cutter, creates the ultimate precision cutting table. The modular design of the Proteus enables growing businesses to quickly and economically reconfigure and expand their bench as needed. No extra tools are necessary, assembly is very simple, and the applications are endless. The Proteus Workbench also functions as a general workbench. Any bench or table unit can be fitted with the customer-supplied top of choice, although a 3/4" thick MDF or finished plywood is recommended.



**PROTEUS WORKBENCH**  
Proteus shown with Javelin Integra. Worktop not included. 3/4" MDF board recommended.

## PROTEUS WORKBENCH

MODEL #	OVERALL SIZE	CUTTER SIZE
60937	78 3/4" x 48" x 35 1/2"	64"
60938	98 1/2" x 48" x 35 1/2"	84"
60939	118" x 48" x 35 1/2"	104"
60940	137 3/4" x 48" x 35 1/2"	124"
60941	157 1/2" x 48" x 35 1/2"	144"



# Precision Safety Straight Edges

Keencut Precision Safety Straight Edge rulers are the only rulers in the sign and graphics industry with guaranteed accuracy. Exceptional straightness provides accurate cutting to within 1mm. The strong, precise and portable laser-true steel tip straight edge, in silver anodized aluminum, is perfect for marking, drawing, scoring or cutting.



**PROTECT THE OPERATOR**  
The full length curved finger guard of the Precision Safety Straight Edge maximizes workplace safety. Operators of all levels can use the Precision Safety Straight Edge safely and efficiently. Easy to read, non-reflective full-length scale for accurate measurements.



**PROTECT YOUR WORK**  
The slightly concave design of the Precision Safety Straight Edge grips the surface and prevents slipping when hand pressure is applied. Two full-length silicone grip cords enable the Precision Safety Straight Edge to grip work without damaging sensitive printed surfaces.

INCHES		METRIC	
MODEL #	SIZE	MODEL	SIZE
60008	18"	60009	45cm
60000	24"	60010	60cm
60001	30"	60011	75cm
60002	36"	60012	90cm
60003	42"	60013	105cm
60004	48"	60014	120cm
60005	54"	60015	135cm
60006	60"	60016	150cm
60007	72"	60017	180cm

## PROTECT THE PRECISION SAFETY STRAIGHT EDGE AND TOOLS

- Embedded steel edge to resist wear
- Lightweight yet durable high-tensile aerospace aluminum alloy frame
- Machined hole for safe and convenient wall-mounting storage
- Quality anodizing for long life and neat appearance
- 100% manufactured by Keencut technicians in England
- 99.98% of materials from the best suppliers in Western Europe



## SIGN MAKING & WIDE FORMAT GRAPHICS

Precision Cutter Bars, Straight Edges & Fabric Cutters

# Sabre Series 2

## ALL PURPOSE CUTTER

The All Purpose Cutter is designed for space saving, precision and portability, for both one-off and volume production. The ergonomic cutting head design requires less operator effort, because the downward pressure goes directly into the blade and substrate. The Sabre Series 2 one-piece lift arm stays in alignment and is accurate to within 0.03" over the full length of the cutter.

THE SABRE SERIES 2 holds work securely, thanks to a full-length silicone rubber grip strip mounted in the surface of the base, plus two more on the underside of the cutter bar. It may be used on a bench or attached to the optional stand or stand package.

### SABRE SERIES 2

The Sabre Series 2 features a 5-year general warranty and a 20-year warranty on the cutting head bearings.



**SERIES 2 CUTTING HEAD**  
MODEL #60394  
High-Performance Cutting Head. Tools interchange quickly for maximum productivity.

### SABRE SERIES 2 INCLUDES 3 CUTTING HEADS



1

#### GRAPHIK BLADE HOLDER

MODEL #60396

Unique reversible blades make it easy for both left- and right-handed operators to cut material up to 1/2" thick. A specially designed knife edge provides extra stability when cutting tougher materials like 1/2" Gatorboard®.



2

#### MEDIUM-DUTY BLADE HOLDER

MODEL #60395

The medium-duty utility blade holder accepts standard utility blades and cuts up to 3/8" thick material.



3

#### TEXTILE BLADE HOLDER

MODEL #60397

Cold cuts textiles and other delicate materials. Ideal for trimming thin strips off banners and posters where a knife blade would be too aggressive.



### INTEGRAL BASEPLATE AND HINGE ARMS

- The innovative hinge and lift arm mechanism permits cutting materials that are longer than the length of the cutter.
- Self-leveling hinge arms accept materials up to 1/2" thick without affecting the cut angle.
- The extruded anodized aluminum base incorporates a narrow groove to accept the blade tip when cutting.



# Stands, Stand Packs & Accessories

## MIX AND MATCH

For added convenience and maximum flexibility, combine a Stand or Stand Pack with a compatible Sabre Series 2 cutter.

The quality Keencut steel stand with its smooth black finish brings the cutter to a comfortable 36" H waist height. The Stand Package includes the standard 36" high steel stand, but also adds a waste catcher that collects off cuts into a neat catch basin, as well as a roll feeder bar positioned between the stand legs that allows users to cut directly from roll media.

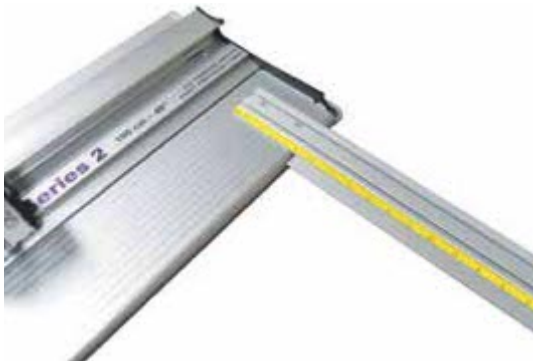

SABRE SERIES 2  
EXTENDED MEASURING ARM



SABRE SERIES 2  
ON STAND

## ADDITIONAL MODELS & ACCESSORIES

### OPTIONAL ACCESSORIES & BLADES FOR

MODEL #	DESCRIPTION
69131	Graphik D 0.017" blades (100)
69108	Medium-duty blades (100)
69119	Superior quality blades (100)
69132	45mm OLFA cutting wheels (10)
69133	45mm standard cutting wheels (10)
60394	Replacement Series 2 Cutting Head
KX15	White silicone cord (Pack of 32')
KX12	Yellow "T" silicone cord (Pack of 32')
69210	36" extended measuring arm

### SABRE SERIES 2 ALL PURPOSE CUTTER

MODEL #	CUT SIZE	OVERALL SIZE
60735	40"	45"W x 13"D x 2¼"H
60736	60"	65"W x 13"D x 2¼"H
60737	80"	84½"W x 13"D x 2¼"H
60738	100"	104"W x 13"D x 2¼"H
60739	120"	124"W x 13"D x 2¼"H

### STAND ONLY

MODEL #	FITS SABRE 2
62361	60735
62364	60736
62366	60737
62367	60738
62368	60739

### STAND PACKAGE: STAND, WASTE CATCHER, ROLL FEEDER KIT

MODEL #	FITS SABRE 2
62351	60735
62354	60736
62356	60737
62358	60738
62359	60739

## QUICK LOOK

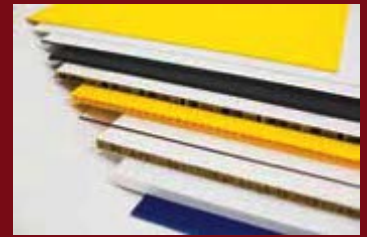

CUTS ALL THESE MATERIALS  
AND MORE.

PERFECT FOR CUTTING  
UP TO 1/2":

- Acrylic (score & snap up to ¼")
- Corrugated plastic
- Foam board
- Film
- Tissue
- Banners
- Fabric and Textiles

### INCLUDES:

- Vertical Graphik blade holder
- Graphik D 0.017" blades (10)
- Textile blade holder with 45mm cutting wheel
- Vertical medium-duty blade holder
- Medium-duty blades (100)

*See our Warranty Guide  
on the back cover.*

# HSGM Hot Cut System

Designed specifically for fabric graphics cutting and finishing, Foster HSGM Hot Cut offers a standard of straight, square and clean cutting.



## WHAT YOU CAN EXPECT FROM THE HOT CUT:

**ACCURACY** Human errors and makeshift straight edges are now a thing of the past. With a single Allen key adjustment, the Keencut Heat Knife Carrier attaches directly to your Foster Keencut cutter bar. The heat knife cuts approximately 1/4 inch from the cutter aluminum extrusion bar, ensuring precision straight-line fabric cuts in the same location every time.

**SPEED** Accommodate today's high-demand fabric graphics—and more of them—using the heated blades of HSGM knives that cut and seal the edges of synthetic fabrics. Eliminate the time associated with cumbersome hand cutting and final trimming of frayed or unraveled edges.

**SAFETY** The Keencut Heat Knife Carrier is safe to use. When the spring-loaded heat knife is depressed, a center post triggers the heating mechanism. As soon as it is released, the heating element automatically turns off.

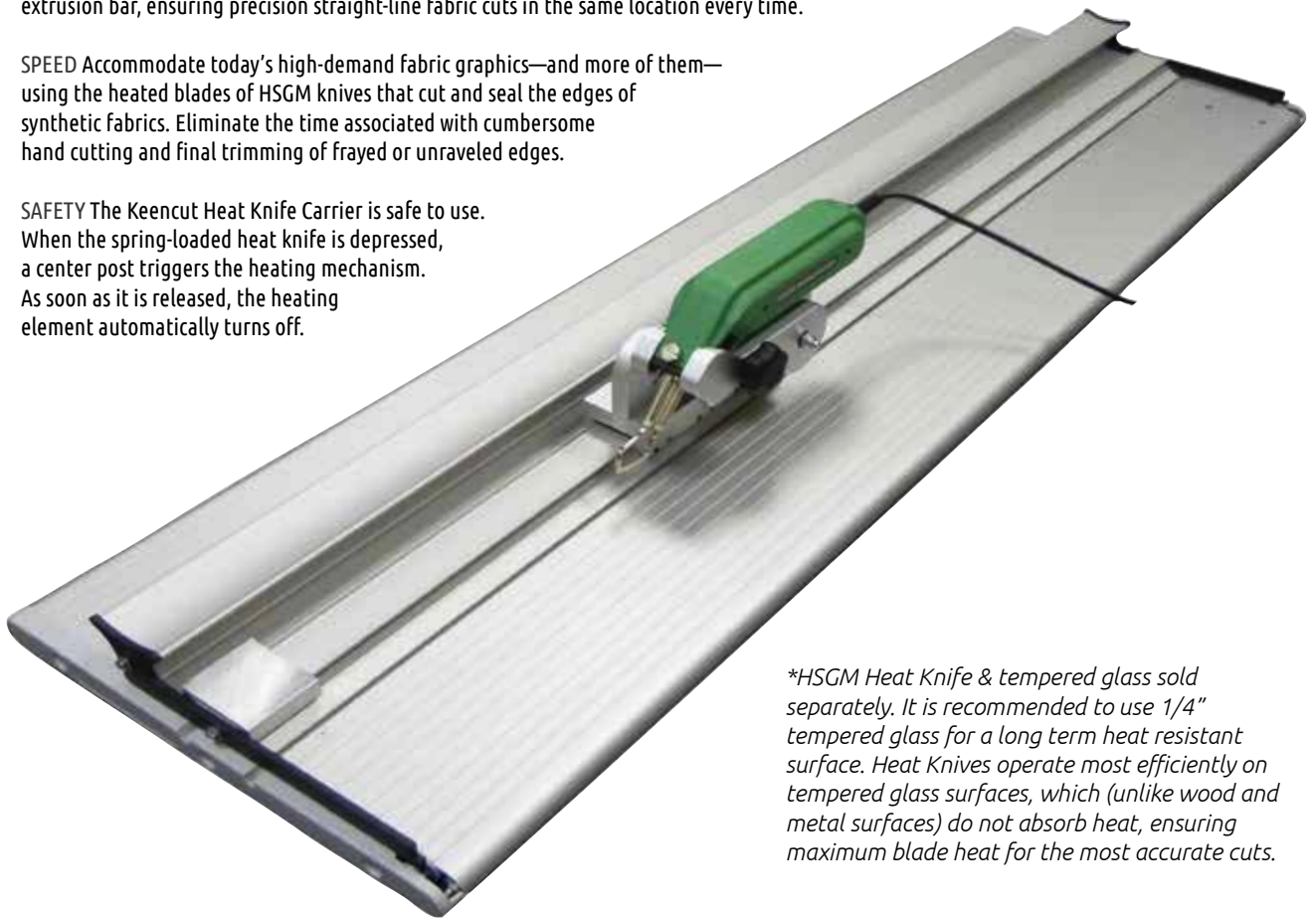

*\*HSGM Heat Knife & tempered glass sold separately. It is recommended to use 1/4" tempered glass for a long term heat resistant surface. Heat Knives operate most efficiently on tempered glass surfaces, which (unlike wood and metal surfaces) do not absorb heat, ensuring maximum blade heat for the most accurate cuts.*

### HOT CUT SYSTEM (HSGM)

MODEL #	CUT SIZE	OVERALL SIZE
61735	36"	46½" L x 13" W
61737	75"	85¾" L x 13" W
61739	115"	125" L x 13" W

#### INCLUDES

- Sabre Cutter Bar and Base
- Heat Knife Carrier
- Silicone Tape\*

### HOT CUT AND HSGM KNIFE PACKAGE

MODEL #	CUT SIZE	OVERALL SIZE
61745	36"	46½" L X 13" W
61747	75"	85¾" L X 13" W
61749	115"	125" L X 13" W

#### INCLUDES

- Sabre Cutter Bar and Base
- HSGM Heat Knife
- HSO-N Blade
- Heat Knife Carrier
- Type R Blade
- Silicone Tape\*

### HOT CUT SYSTEM (AZTC)

MODEL #	CUT SIZE	OVERALL SIZE
61725	36"	46½" L x 13" W
61727	75"	85¾" L x 13" W
61729	115"	125" L x 13" W

#### INCLUDES

- Sabre Cutter Bar and Base
- Heat Knife Carrier
- Silicone Tape\*

# Heat Knife Models & Accessories



## HSGM HEAT KNIFE MODEL #67100

### HSGM Heat Knife Use and Specifications

- Blade heat time: 6-8 seconds
- Blade temperature: approx. 1100° Fahrenheit (600°C).
- Electrical: Uses 120 V, 60 W
- Heat Knife and tempered glass (¼" recommended) sold separately.

Heat knives operate most efficiently on tempered glass surfaces, which (unlike wood and metal surfaces) do not absorb heat, ensuring maximum blade heat for the most accurate cuts.

## HSGM KNIFE & BLADES

MODEL #	DESCRIPTION
67100	HSGM Heat Knife*
67101	HSO-N Blade: Fine tip
67102	Type R Blade: Broad tip

\*Blade not included

See our Quick Reference Blade Guide on p. 38-39.



## HSGM HEAT KNIFE CARRIER MODEL #60398



## AZTC HEAT KNIFE CARRIER MODEL #60399

THE KEENCUT HEAT KNIFE CARRIER fits all mounted Keencut cutter bars. The HSGM carrier device accepts the HSGM HSG-0 heat knives; the AZTC carrier accepts AZTC heat knives.

Heat knives not included. Foster does not carry the AZTC heat knife or blades.

## QUICK LOOK



### PERFECT FOR CUTTING:

- Synthetic Fabric
- Webbing
- Ropes (17mm maximum diameter)

### WORKS WITH KEENCUT CUTTER BARS:

- Evolution Series 1 and 2
- Sabre Series 1 and 2
- Javelin Integra
- Javelin Series 1 and 2 when mounted to a Big Bench or Stand

## OPTIONAL STANDS

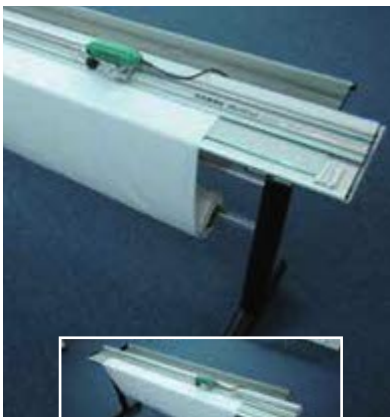

### STAND ONLY

MODEL #	FITS HSGM HOT CUT	FITS AZTC HOT CUT
62361	61735	61725
62366	61737	61727
62368	61739	61729

### STAND PACKAGE: STAND, WASTE CATCHER, ROLL FEEDER KIT

MODEL #	FITS HSGM HOT CUT	FITS AZTC HOT CUT
62351	61735	61725
62356	61737	61727
62359	61739	61729

See our Warranty Guide on the back cover.

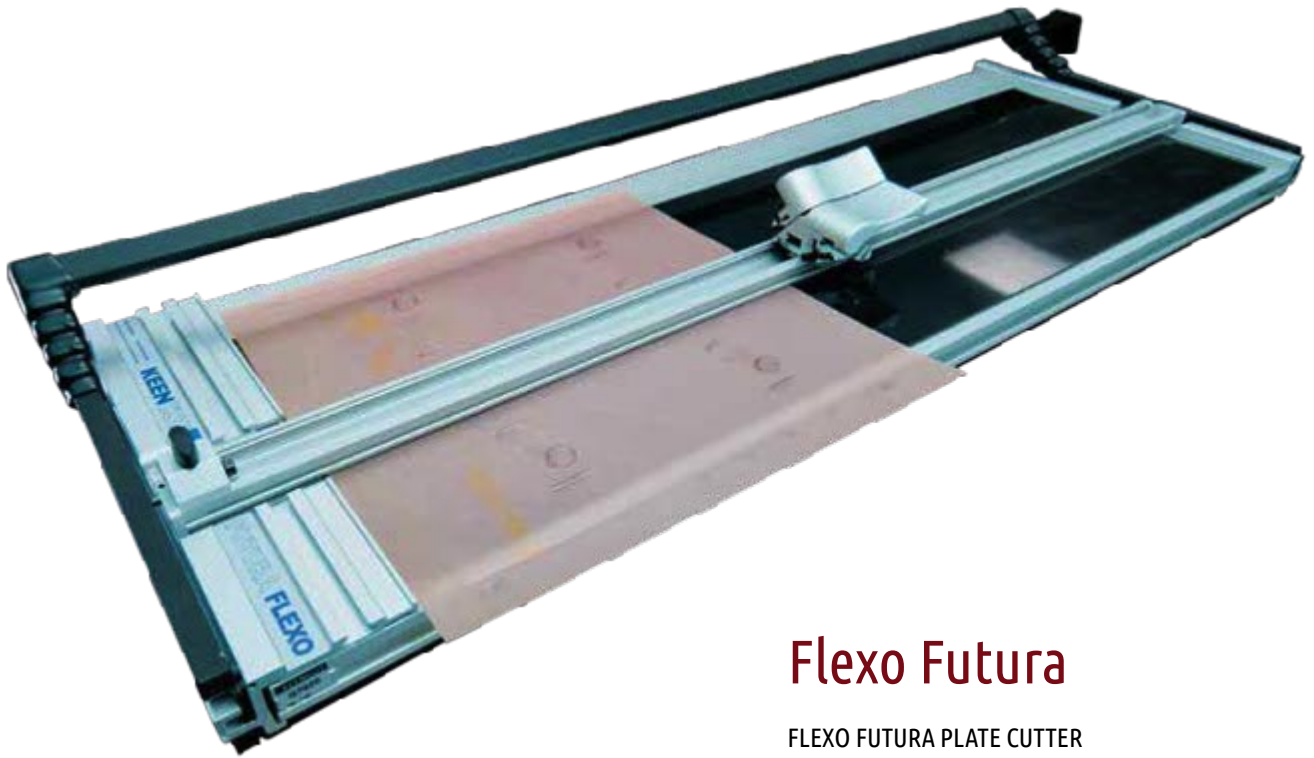

## Flexo Futura

### FLE XO FUTURA PLATE CUTTER

Designed specifically for cutting flexo printing plates, the Keencut Flexo Futura Plate Cutter eliminates the onerous task of hand beveling, minimizing the risk of injury from remakes and bad cuts. It is also perfectly designed for cutting and trimming floor graphics or other materials requiring a seamless splice.

The Keencut Flexo Futura Plate Cutter yields incredible cost savings simply by eliminating manual errors. No more improper hand-cut bevels that result in gaps between splices. No more filling and taping hand cuts, creating stress points that can release during a press run. No more plates lifting off the printing cylinder and destroying themselves.



### FLE XO FUTURA PLATE CUTTER FEATURES

**ERGONOMICALLY DESIGNED FUTURA CUTTING HEAD**  
Makes it easy to use over long periods. And it is comfortable for left-or right-handed users.



**High Performance STEEL ROLLER BEARINGS**  
The Flexo Futura cutting head features a set of built-in self-aligning ball bearing rollers operating on twin steel tracks, designed for a lifetime of straight, accurate, silent cutting. The cutting head and track are designed to handle dense, hard-to-cut materials. No flex, side play or hooks.

### FLE XO FUTURA

MODEL #	CUT SIZE	OVERALL SIZE
61808	40"	47" W X 15½" D
61812	48"	54¾" W X 15½" D
61816	62"	68½" W X 15½" D
61820	86"	94" W X 15½" D

*See our Warranty Guide on the back cover.*



**LIFT AND HOLD SYSTEM:**  
**MODEL #61832**  
 Raises or lowers the cutter bar and frees both hands for setting up projects.

**REPLACEMENT BLADES**

MODEL #	DESCRIPTION
69108	Medium-duty blades (100)
69119	Super quality blades (100)

See our Quick Reference Blade Guide on p. 38-39.

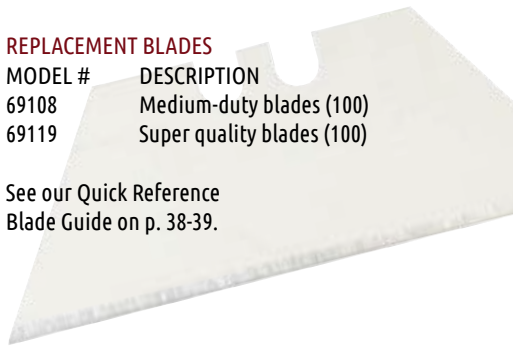

**FLEXO FUTURA SQUARING ARM:**  
**MODEL #61832**  
 Ideal for accurately sizing and squaring substrates.



**CUTTING FENCE:**  
**MODEL #61830**  
 Provides a guide to cut up against when production cutting boards down to a preset size. Ideal when cutting parallel strips.



**60CM SUPPORT ARMS:**  
**MODEL #61216**  
 Clip-on base extension arms to increase the effective width of the base to 100cm (39") to hold large boards flat and square by preventing sag.

**EXTRA MAGNETIC BLADE HOLDERS:**



**MODEL #61340**  
 Bevel Blade Cartridge



**MODEL #61341**  
 Vertical Blade Cartridge

Both the bevel and vertical blade holders are fitted with quick-release magnetic blade cartridges. Easily calibrate preset depths and simple blade adjustments.

**QUICK LOOK**

**CUTS ALL THESE MATERIALS AND MORE.**

**PERFECT FOR CUTTING UP TO 6MM:**

- Banners
- Corrugated plastic
- Foam board
- Ink jet media
- Flexo plates
- Mount board

**INCLUDES:**

- Medium-duty utility blades (100)
- Cutting mat

*See our Warranty Guide on the back cover.*



**CUTTING HEAD IS MOUNTED ON ROLLER BEARINGS RUNNING ON STEEL TRACKS.**

Beveled edge and vertical blade holders are spring loaded and retractable when not in use.

# Ultimat Futura

**ULTIMAT FUTURA**  
 ERGONOMIC CUTTING HEAD:  
 EASY, PRECISE and SMOOTH



The **Ultimat Futura** — featuring a new cutting head with self-aligning roller bearings — represents the future of manual mat cutters and offers the smoothest cut ever. The Ultimat Futura builds on the unique versatility, advanced design and precision of the world-leading Ultimat Gold to take manual mount cutting to the ultimate of accurate, fast operation on modern mount board of every type and thickness.

THE ULTIMAT FUTURA INCLUDES

- Switchable magnetic blade holders for cutting different thicknesses.
- Large-diameter roller thrust bearings on the cutting head for total control of both blade carriers.
- No flex, side play or hooks.
- Base plate that accommodates all accessories.
- Roller lift and hold system.
- Patented micro-stops.

## OUTSTANDING FEATURES OF THE ULTIMAT FUTURA



Easy-to-change blade cartridges for switching between cutting materials in seconds.

Ergonomically designed cutting head makes use over long periods comfortable for left- or right-handed users.



Roller 'lift and hold' system with one-handed operation raises or lowers the cutter bar and frees hands for precise mat placement without need to hold up the lifting handle.



Sliding gauge pinpoints blade entry and exit spot for exact freehand cutting.

Patented micro stop adjusters fitted to the 'start of cut,' 'end of cut' and 'margin guide' stops allow you to dial out overcuts or undercuts in seconds.



Features an all-new cutting head with built-in self-aligning ball bearing rollers operating on twin steel tracks to deliver a slide action that is smooth, precise and has no discernible friction under load.

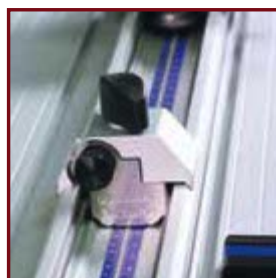

New high-performance slideway and head system uses Keencut SteelTraK technology.



Maximum operator effort is transmitted to the blade to put the cutting of even 8-ply mount board within the capability of every framer.

# Ultimat Gold

The **Ultimat Gold** — Tough, precise, built to last and exceptionally comfortable to use, the Keencut Ultimat Gold takes the guesswork out of creating perfect mats. The Ultimat Gold is the gold standard of manual mat cutters for both highly skilled hobbyists and professionals who specialize in intricate frames.

Offering superior micro-adjustments and space-age bearings that provide silent-glide action, the Ultimat Gold is built for precision, ease of use and versatility.



### UNRIVALED FEATURES AND DUAL CUTTING HEAD

- The precision cutting head has a comfortable sculpted shape and features ball-and-thrust bearings for superb precision.
- The dual cutting head features both beveled edge and vertical blade holders.
- The vertical head locks into position, permitting easy cutting of the thickest boards.

### ADDITIONAL MODELS & ACCESSORIES

#### ULTIMAT FUTURA

MODEL #	CUT SIZE	OVERALL SIZE
61310	40"	47"W X 15½"D
61312	48"	54¾"W X 15½"D
61314	60.5"	68½"W X 15½"D

#### ULTIMAT GOLD

MODEL #	CUT SIZE	OVERALL SIZE
61210	40"	47"W X 15½"D
61212	48"	54¾"W X 15½"D
61214	60.5"	68½"W X 15½"D

#### ACCESSORIES

MODEL #	DESCRIPTION
61216	2x Base Extension Support Arm 24" Long
61218	30" Extended Margin Guide Kit
61220	Multi-Angle Cutting Gauge
61224	Reverse Bevel Stop
61340	Extra Futura Bevel Blade Cartridge
61341	Extra Futura Vertical Blade Cartridge

See our Quick Reference Blade Guide on p. 38-39.

#### REPLACEMENT BLADES

MODEL #	DESCRIPTION
69108	Medium-duty blades (100)
69119	Superior quality blades (100)
61199	Tech S .012 blades (100)

MODEL #	DESCRIPTION
69137	Tech S .015 blades (100)
69136	Tech D .012 blades (100)
69135	Tech D .015 blades (100)

#### UPGRADE FOR ULTIMAT GOLD

MODEL #	CUT SIZE
61320	40"
61321	48"
61322	60.5"

#### UPGRADE FOR ULTIMAT PURPLE

MODEL #	CUT SIZE
61330	40"
61331	48"
61332	60.5"

## QUICK LOOK

CUTS ALL THESE MATERIALS AND MORE.

PERFECT FOR CUTTING UP TO 3/8":

- Banners
- Foam board (5mm)
- Conservation board
- Corrugated plastic (5mm)
- Mat board
- Mount board
- Self-adhesive vinyl

### INCLUDES:

- Tech D .012 blades (30)
- Superior quality blades (20)
- Tech S .012 blades (15) (Futura only)
- Tech S .015 blades (15) (Futura only)

### UPGRADE KITS FOR ULTIMAT GOLD & ULTIMAT PURPLE:

The good news for any current owner of the original Ultimat or Ultimat Gold: The Futura slideway, cutting head and stop system have been specifically designed to retrofit existing machines.

### INCLUDES:

- Futura Slideway
- Futura Cutting Head
- Micro Stop System

See our Warranty Guide on the back cover.

## ARC & TE

**THE KEENCUT ADVANCED ROTARY CUTTER (ARC)** is the only rotary trimmer with dual cutting wheels, providing two-way cutting flexibility and guaranteed sharpness with tungsten steel blades. The unique monorail bearing system design, positioned beneath the surface of the baseboard, makes the ARC specifically suited for cutting even the thinnest of materials without their buckling on the edge of the blade. Additionally, the ARC guarantees a consistent cut over the entire length of the material; no bows or buckles in the middle.



**ADVANCED  
ROTARY CUTTER**



**TABLE-EDGE  
ROTARY TRIMMER**

### **TABLE-EDGE ROTARY TRIMMER (TE)**

When space is at a premium, the Keencut Table-Edge Rotary Trimmer is the perfect solution for cutting large-format materials, turning an existing table into a complete print finishing station. The mounting plate, with predrilled, countersunk holes, butts flush to the edge of a table. The Table-Edge Rotary Trimmer cuts in both directions using the same patented technology as the ARC, with the added advantage of increasing the working area, enabling easy alignment and effortless one-handed trimming.



**ARC REPLACEMENT CUTTING HEAD  
MODEL #69122**

### **UNIQUE FEATURES**

- Patented subsurface monorail bearing system
- Twin Tungsten Steel Cutting Wheels are combined with a full-length fixed blade strip
- Mechanism will not distort even under heavy pressure
- Two clamp rollers provide clamping during the cutting process
- No overhead rail to obstruct visibility of cut-line



# Stands, Stand Packs & Accessories

FOR ADDED CONVENIENCE AND MAXIMUM FLEXIBILITY, COMBINE A STAND OR STAND PACK WITH A COMPATIBLE ADVANCED ROTARY CUTTER.

The quality Keencut steel stand with its smooth black finish brings the cutter to a comfortable 36" H waist height. The Stand Package includes the standard 36" high steel stand, but also adds a waste catcher that collects off cuts into a neat catch basin, as well as a roll feeder bar positioned between the stand legs that enables users to cut directly from roll media.

ARC ON  
STAND PACK



## OPTIONAL 36" EXTENDED MEASURING ARM

MODEL #69208

- Improve accuracy and versatility
- Comes complete with measuring stop
- One size: 91cm (36")



## REPLACEMENT BLADES & ACCESSORIES

MODEL #	DESCRIPTION
69208	36" extended measuring arm
69122	Replacement cutting head
69124	Replacement cutting wheels for black cutting head only

See our Quick Reference Blade Guide on p. 38-39.

## TABLE-EDGE ROTARY TRIMMER (TE)

MODEL #	CUT SIZE	OVERALL SIZE
60630	40"	52½"W x 5¼"D x 2¾"H
60631	60"	70½"W x 5¼"D x 2¾"H
60632	80"	91"W x 5¼"D x 2¾"H
60633	100"	110¼"W x 5¼"D x 2¾"H
60634	120"	130¾"W x 5¼"D x 2¾"H

## STAND ONLY

MODEL #	FITS ARC
62362	60606
62365	60609
62366	60613
62367	60611
62368	60612

## ADVANCED ROTARY CUTTER (ARC)

MODEL #	CUT SIZE	OVERALL SIZE
60606	42"	52½"W x 17"D x 2½"H
60609	60"	70½"W x 17"D x 2½"H
60613	80"	91"W x 17"D x 2½"H
60611	100"	110¼"W x 17"D x 2½"H
60612	120"	130¾"W x 17"D x 2½"H

## STAND PACKAGE: STAND, WASTE CATCHER, ROLL FEEDER KIT

MODEL #	FITS ARC
62322	60606
62355	60609
62356	60613
62358	60611
62359	60612

## QUICK LOOK



## ADVANCED ROTARY CUTTER (ARC) & TABLE-EDGE (TE)

### PERFECT FOR CUTTING:

- Aluminum plate (0.004")
- Banner
- Card
- Cellophane
- Cibachrome
- Cork
- Corrugated card
- Digital prints
- Encapsulations
- Film
- Floor graphics
- Heatseal
- Ink jet paper
- Laminations
- Photo Paper
- Photo film
- Polystyrene
- Posters
- Self-adhesive film
- Tissue paper
- Transparencies
- Vinyl

### INCLUDES:

- Two cutting wheel heads

*See our Warranty Guide on the back cover.*

# DigiTech+ & Professional

## ROTATRIM DIGITECH+

The Rotatrim DigiTech+ is a heavy-duty trimmer drawing on the design elements of the proven Professional (below). It offers the same dynamic features as the Professional, in a very large format cutting up to 100". Using the same self-sharpening, hand-finished tungsten steel blades as the Professional, the DigiTech+, like all Rotatrim trimmers, is engineered for total cut precision.

- A strong 1¼" stainless steel guide rail provides cutting head stability.
- A single roller mechanism results in lighter cutting action (maximum cut depth of 2mm).
- The extruded aluminum baseboard, end frames and head — plus square side rule — ensure extreme robustness.
- An auto-lifting clamping mechanism locks materials into place as the head begins to cut, then automatically releases when the cut is complete, preventing material and substrate scratching.

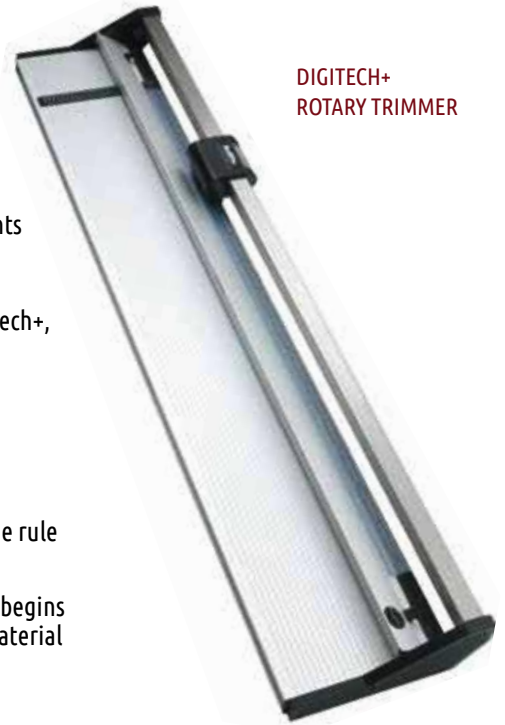

DIGITECH+  
ROTARY TRIMMER

## DIGITECH+

MODEL #	CUT SIZE	OVERALL SIZE
60301	26"	40"W x 13½"D x 7"H
60311	38"	52"W x 13½"D x 7"H
60321	49"	64"W x 13½"D x 7"H
60331	61"	75½"W x 13½"D x 7"H
60341	73"	87½"W x 13½"D x 7"H
60361	100"	113"W x 13½"D x 7"H

## PROFESSIONAL ROTARY TRIMMER

The heavy duty Rotatrim Professional consistently proves its durability and value as an "all day, every day" trimmer in a number of industries. It is used to cut offset printing plates, packaging materials, polyethylene, even mount board — and for general office finishing projects.

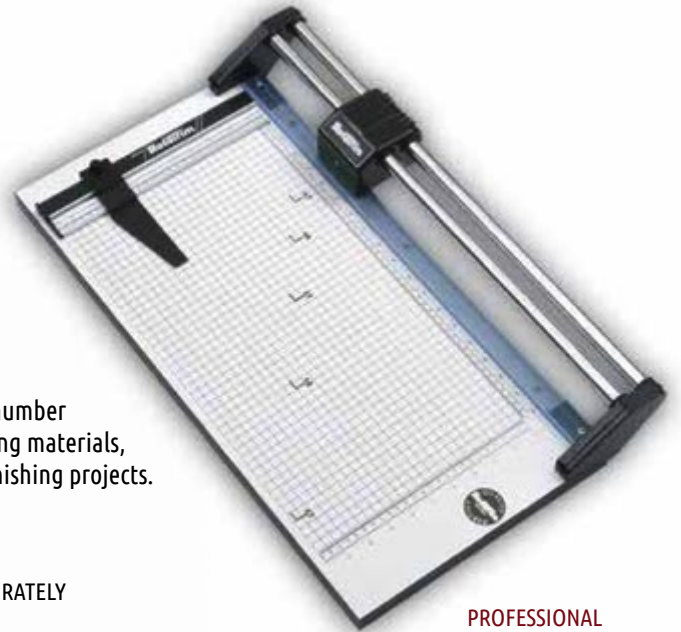

PROFESSIONAL  
ROTARY TRIMMER

FROM MOUNT BOARD TO TISSUE PAPER, THE PROFESSIONAL ACCURATELY CUTS ANY SUBSTRATE WITHOUT A SINGLE MACHINE ADJUSTMENT.

The Professional is perfect for production cutting and trimming of flexible materials, offering a smooth cutting action.

- Dual chrome-plated guide rails eliminate cutting head swivel.
- Maximum cut depth of 3mm.
- A solid laminated gridded baseboard ensures accurate work placement.
- All-metal end frames and head, and an aluminum square side rule, yields a lifetime of performance.

## PROFESSIONAL

MODEL #	CUT SIZE	OVERALL SIZE
60100	12"	18½"W X 15¾"D X 6"H
60110	15"	21½"W X 15¾"D X 6"H
60120	18"	24"W X 15¾"D X 6"H
60125	20"	26"W X 15¾"D X 6"H
60130	24"	31"W X 15¾"D X 6"H
60140	30"	36½"W X 15¾"D X 6"H
60150	36"	42½"W X 15¾"D X 6"H
60160	42"	49"W X 15¾"D X 6"H
60170	54"	61"W X 15¾"D X 6"H

See our Warranty Guide on the back cover.

# MonoRail & Accessories

## ROTATRIM MONORAIL

The Monorail is designed for the slightly more occasional user: the professional seeking a quality trimmer that will not be used all day, every day. Or maybe a photo or framing enthusiast who wants the best but doesn't need the durability of a heavier duty trimmer. Or perhaps someone in education in need of a premium machine, but without the premium price.



ROTATRIM  
MONORAIL

The Monorail is perfect for moderate cutting and trimming of flexible materials, and offers smooth-glide cutting action:

- A single chrome plated guide rail is extremely resistant to head swivel.
- Design offers a maximum cut depth of up to 2mm.
- A solid laminated gridded baseboard ensures accurate work placement.
- Virtually indestructible ABS plastic end frames and head are designed for 20 to 25 years of performance.

## MONORAIL

MODEL #	CUT SIZE	OVERALL SIZE
60210	19"	26 <sup>1</sup> / <sub>4</sub> "W x 15 <sup>3</sup> / <sub>4</sub> "D x 4"H
60220	26 <sup>3</sup> / <sub>4</sub> "	34 <sup>1</sup> / <sub>4</sub> "W x 15 <sup>3</sup> / <sub>4</sub> "D x 4"H
60222	37"	44 <sup>1</sup> / <sub>2</sub> "W x 15 <sup>3</sup> / <sub>4</sub> "D x 4"H
60223	50"	57"W x 15 <sup>3</sup> / <sub>4</sub> "D x 4"H



36" RULE EXTENSION  
FOR PROFESSIONAL  
MODEL #62325

## ACCESSORIES

ROTATRIM STAND & WASTE CATCHER FOR USE WITH PROFESSIONAL AND DIGITECH+

### STAND PACKAGE & WASTE CATCHER

MODEL	FOR DIGITECH
62810	60301
62812	60311
62814	60321
62816	60331
62818	60341
62822	60361

SHOWN WITH  
PROFESSIONAL



### STAND PACKAGE & WASTE CATCHER

MODEL	FOR PROFESSIONAL	SIZE
62800	60140	30"
62802	60150	36"
62804	60160	42"
62806	60170	54"

### REPLACEMENT CUTTING WHEELS & ACCESSORIES

MODEL	DESCRIPTION
69105	Replacement cutting wheel
62325	36" rule extension for Professional

See our Quick Reference Blade Guide on p. 38-39.

## QUICK LOOK



PROFESSIONAL  
CUTS UP TO 3MM

MONORAIL  
CUTS UP TO 2MM

Perfect for Cutting:

- Card
- Cellophane
- Cibachrome
- Cork
- Corrugated card
- Digital prints
- Encapsulations
- Felt
- Floor graphics
- Heatseal
- Ink jet paper
- Laminations
- Photo paper
- Photo film
- Polyester
- Polystyrene
- Posters
- Reflective film
- Self-adhesive film
- Tissue paper
- Transparencies
- Veneers
- Vinyl

INCLUDES:

- Sheffield Steel Cutting Wheel



**POWERTECH ROTARY TRIMMER**  
Trimmer Voltage: 120V



**TECHNICAL ROTARY TRIMMER**

**ROTATRIM TECHNICAL**

The Rotatrim Technical is identical in form to the DigiTech+ (above), with an added triple roller mechanism to provide extreme down force for cutting heavy materials. Also featured are special Sheffield tool steel blades, providing enhanced durability under extreme operational loads. High chromium content makes these blades exceptionally slow-wearing, even when cutting the most abrasive materials.

The Rotatrim Technical is an extremely heavy duty rotary trimmer capable of cutting the widest array of substrates and materials. For cutting flexible to heavy duty semi-rigid materials, this large format trimmer (up to 100") is the answer — perfect for high-volume cutting and trimming.

## PowerTech & Technical

**ROTATRIM POWERTECH**

The Rotatrim PowerTech is a powered version of the Technical (below), complete with a foot operated switch. High volume, large-format shops will quickly recoup their investment by reducing manpower and increasing productivity.

- The PowerTech frees both hands and lessens operator fatigue.
- The trimmer is electrically driven through a long-lasting steel reinforced belt.
- Higher cutting head speed (0.5m/second) makes the PowerTech ideal for trimming heavy materials. (Higher speed versions — up to 1.0m/second and ideal for lighter materials up to 1mm thick — are available.
- Maximum cut depth: 3mm.



PowerTech cuts up to 3mm flexible substrates



Technical Triple Roller

- A single 1½" stainless steel guide rail completely eliminates head swivel.
- All-metal construction (and extruded aluminum baseboard, end frames and head) ensure durability.
- An auto-lifting clamping mechanism locks materials into place as the head begins to cut, then automatically releases at the completion of the cut, preventing material and substrate scratching.
- Maximum cut depth of up to 4mm.

# Stand & Accessories

## ROTATRIM STAND & WASTE CATCHER For use with DIGITECH+, TECHNICAL and POWERTECH CUTTERS

This convenient quality steel stand supports Rotatrim DigiTech+, PowerTech and Technical Series trimmers, providing rigid support at the ideal working height of 34 inches. Black finished, this stand includes an integrated, transparent space-saving waste catcher that collects off-cuts.



### STAND PACKAGE AND WASTE CATCHER FOR TECHNICAL, DIGITECH+, POWERTECH

MODEL #	TECHNICAL	DIGITECH+	POWERTECH
62810	60300	60301	—
62812	60310	60311	60400
62814	60320	60321	60405
62816	60330	60331	60410
62818	60340	60341	60420
62819	60350	—	60430
62822	60360	60361	60440 & 60450

### ADDITIONAL MODELS & ACCESSORIES

#### REPLACEMENT CUTTING WHEELS & ACCESSORIES

MODEL #	DESCRIPTION
69105	Replacement cutting wheel for DigiTech+
69305	Replacement cutting wheel for Technical and PowerTech
62326	36" rule extension

See our Quick Reference Blade Guide on p. 38-39.

#### POWERTECH

MODEL #	CUT SIZE	OVERALL SIZE
60400	26"	55"W x 13½"D x 7"H
60405	38"	67"W x 13½"D x 7"H
60410	49"	78½"W x 13½"D x 7"H
60420	61"	90½"W x 13½"D x 7"H
60430	73"	102"W x 13½"D x 7"H
60440	85"	114"W x 13½"D x 7"H
60450	100"	128"W x 13½"D x 7"H

#### TECHNICAL

MODEL #	CUT SIZE	OVERALL SIZE
60300	26"	40"W x 13½"D x 7"H
60310	38"	52"W x 13½"D x 7"H
60320	49"	64"W x 13½"D x 7"H
60330	61"	75½"W x 13½"D x 7"H
60340	73"	87½"W x 13½"D x 7"H
60350	85"	100"W x 13½"D x 7"H
60360	100"	113"W x 13½"D x 7"H

## QUICK LOOK



CUTS ALL THESE MATERIALS  
AND MORE.

DIGITECH+ CUTS UP TO 2MM  
POWERTECH CUTS UP TO 3MM  
TECHNICAL CUTS UP TO 4MM











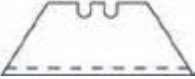

Perfect for Cutting:

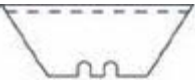
- Aluminum (0.5mm max)
- Banners
- Canvas
- Card
- Cork
- Digital prints
- Flexographic plates (0.067" max)
- Foamex (1mm max)
- Foil
- Leather
- Lithoplate
- Magnetic vinyl
- Masonite (2mm max)
- MDF (2mm max)
- Mount board
- Photo paper
- Photo film
- Polystyrene
- Posters
- Self-adhesive film
- Tissue paper
- Veneers

INCLUDES:

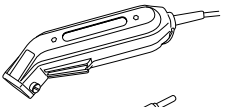
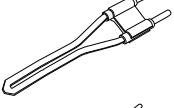
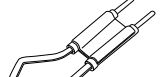

- Sheffield Steel Cutting Wheel

# QUICK REFERENCE BLADE GUIDE

	UTILITY BLADES	Box of	Part Number	Artist*/Artist Plus*	Evolution*	Evolution E2 (p.8)	Excaliber 5000 & 1000x (p.18)	Flexo*/Flexo Futura Cutter (p.22)	Javelin Series 2 (p.14)
	<b>MEDIUM DUTY - CA50/019</b> This blade is used for cutting standard material up to 3/8" (0.375) thick.	100	69108	✓	✓	✓	✓	✓	✓
	<b>SUPERIOR QUALITY - CA50/010</b> Made out of surgical grade steel, this blade has a superior edge for performance cutting. (0.375) thick.	100	69119	✓	✓	✓	✓	✓	✓
	<b>KEENCUT XR - CA50/027</b> The XR long blade is used for cutting standard material up to 1/2" thick; it is slightly longer than the standard medium-duty utility blade.	100	69120		✓				
	<b>GRAPHIK D.017 - CA50/032</b> Designed to cut a variety of boards up to 1/2" thick, the reversible blades make it ideal for left-handed and right-handed operators.	100	69131			✓			✓
	<b>ACRYLIC SCORING KX33</b> The scoring blade is designed to score acrylics and Plexiglas; then snap along the scoring line.	5	69109		✓				
	<b>TECH D .012</b> This blade creates a double-ground knife-edge cut 0.012" thick.	100	69136	✓				✓	
	<b>TECH D .015</b> This blade creates a double-ground knife-edge cut 0.015" thick.	100	69135	✓				✓	
	<b>TECH S .012</b> This blade creates a single-ground chisel edge cut 0.012" thick.	100	61199	✓				✓	
	<b>TECH S .015</b> This blade creates a single-ground chisel-edge cut 0.015" thick.	100	69137	✓				✓	
	<b>28MM TEXTILE WHEELS</b> The 28mm circular blade is used for cutting textiles, thin paper, fabric and other flimsy materials.	10	69141		✓				
	<b>45MM TEXTILE WHEELS</b> The 45mm OLFA circular blade is used for cutting textiles, thin paper, fabric and other flimsy materials.	10	69132			✓			✓
	<b>45MM STANDARD TEXTILE WHEELS</b> The 45mm standard circular blade is used for cutting textiles, thin paper, fabric and other flimsy materials.	10	69133			✓			✓
	<b>HSGM HEAT KNIFE (blade not included)</b> Can be used with the Heat Knife Carrier on the Keencut cutter bars.	1	67100		✓	✓			✓
	<b>HSON BLADE</b> Fine tip blade with 9mm of heated cutting area is designed for fine fabrics.	1	67101		✓	✓			✓
	<b>TYPE R BLADE</b> Broad tip blade with 1.14" of heated surface is designed for general-use cutting. Cuts straight lines on synthetic fabric easily.	1	67102		✓	✓			✓

\* NOTE: ALL CUTTERS IN RED ARE DISCONTINUED, but blades are still available for purchase.

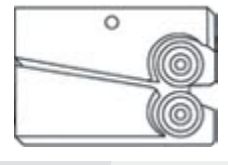
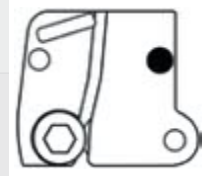
Javelin Integra	Javelin Xtra*	Max*	Sabre Series 2 (p.18)	Sabre*	Simplex/Practik* (p.15)	SteelTraK (p.4)	Ultimat Gold/Ultimat* (p.25)	Ultimat Futura (p.24)
✓	✓	✓	✓	✓	✓	✓	✓	✓
✓	✓	✓	✓	✓	✓	✓	✓	✓
	✓	✓		✓	✓			
✓			✓					
	✓	✓		✓	✓			
						✓	✓	
						✓	✓	
						✓	✓	
						✓	✓	
✓	✓	✓	✓	✓	✓			
✓			✓					
✓			✓					
✓	✓	✓	✓	✓				
✓	✓	✓	✓	✓				

TWIN-WHEEL BLADES			
	Box of	Cutter Assembly Part Number	Replacement Wheels Part Number (1 set of 2 wheels)
EXCALIBUR - TWIN-WHEEL CUTTING HEAD (EXCOC) The twin-wheel head shears 1/8" Masonite, heavy mat board and 3/8" PVC board.	1	69125	69110
			
STEELTRAK COMPOSITE STCOC Included with the SteelTraK, the composite twin-wheel cutting tool can cut up to 4mm Dibond, 3mm MDF and 3mm flexible polycarbonate.	1	69123	69126
			
STEELTRAK ALUMINUM STALC This aluminum twin-wheel cutting tool can cut up to 0.040" aluminum.	1	69127	69128
			
STEELTRAK-REPLACEMENT V-GROOVE BLADE The V-Groove cutting tool enables the folding of aluminum composite, corrugated plastic and PVC board.	1	69142 = 2mm V-Groove Tool 69143 = 3mm V-Groove Tool 69144 = 4mm V-Groove Tool 69146 = 6mm V-Groove Tool	69147
			

ROTARY BLADES	REPLACEMENT WHEEL/SET	REPLACEMENT HEAD ASSEMBLY
Keencut Classic**	68110	KC01/003
Advanced Rotary Cutter ARC	69124*	69122
Table-Edge Rotary Cutter TE	69124*	69122
Rotatrim Professional	69105	M100
Rotatrim Monorail	69105	MCHEAD
Rotatrim Technical Series	69305	T100A
Rotatrim PowerTech	69305	PT152A
Rotatrim DigiTech+	69105	DTHEAD

\*For use with Black Cutting Head only  
\*\*Discontinued cutter (cutting wheel still available)



### GORILLA GRIPPER FOR RIGID SUBSTRATES

When another pair of hands isn't available to grip, lift or carry large sheet and board materials, the Gorilla Gripper can help. This simple device also minimizes or eliminates damage to the edges and corners of large sheets of rigid substrates, saving your shop money and frustration.

Simply slip the Gorilla Gripper over the center of the panel and lift. Carry panels with less fatigue, increased control and unobstructed field of vision. Reduce potential injuries to fingers, hands, wrists and backs.



**THE GORILLA GRIPPER GP**  
(General Purpose) Gripping range from 0" to 3/4" (0 to 21mm). The Gorilla Gripper GP is made of high-strength, aircraft-grade aluminum, with a guaranteed lifting capability of 200 pounds.

**Item 60550**

**THE GORILLA GRIPPER ADVANTAGE**  
Gripping range from 0" to 3/4" (0 to 21mm). The Gorilla Gripper Advantage is made of high-strength, glass-filled nylon polymer. The guaranteed lifting capability is 100 pounds.

**Item 60553**



### MANUFACTURER'S WARRANTIES

#### • FOSTER ON-A-ROLL LIFTERS

The On-a-Roll Lifter® includes a 2-year warranty on all wheels, hydraulics and media tray, and a 5-year warranty on cross bars.

#### • KEENCUT CUTTERS & TRIMMERS

Advanced Rotary Cutter (ARC), Evolution-E2, Excalibur 5000 & 1000x, Sabre Series 2 All Purpose Cutter, SteelTraK, Table Edge Rotary Trimmer, Javelin Series 2, Simplex, Max, Ultimat Gold, Javelin Integra, Ultimat Futura, Flexo Futura, Hot Cut System

All Keencut products include a 5-year parts warranty (excluding blades, clamp strips, site line strips and cutting wheels) and a 20-year warranty on bearings.

#### • ROTATRIM TRIMMERS

DigiTech+, Monorail, PowerTech\*, Professional, Technical All Rotatrim trimmers carry a 5-year parts warranty (excluding cutting wheels, motors and clamping strips).\*

\* The Rotatrim PowerTech, which meets stringent ISO9001:2008 manufacturing standards, carries a one-year warranty under normal use.

### ACCESSORIES

• KEENCUT ACCESSORIES, WORKBENCHES, STORAGE  
BIG BENCH, BIG BENCH XTRA, PROTEUS WORKBENCH, MATBOARD STORAGE, LIFT & HOLD MECHANISM, LASER-TRUED STEEL TIP STRAIGHT EDGES, HEAT KNIFE CARRIER  
All accessories, workbenches and storage units include a 5-year parts warranty.

#### • HSGM HEAT KNIFE

HSGM Heat Knives include a 1-year limited warranty for manufacturer defects.

#### • GORILLA GRIPPER

Gorilla Gripper products carry a lifetime warranty against defects in materials and workmanship.

The guaranteed lifting capability for the Gorilla Gripper is 200 pounds.

### DELIVERY PROMISE

Most products are in stock for immediate shipment through our network of reliable freight carriers – usually within 24 hours.